



e-ISSN: 2319-8753 | p-ISSN: 2347-6710

IJIRSET

International Journal of Innovative Research in
SCIENCE | ENGINEERING | TECHNOLOGY



INTERNATIONAL JOURNAL OF INNOVATIVE RESEARCH

IN SCIENCE | ENGINEERING | TECHNOLOGY

Volume 12, Issue 1, January 2023

ISSN INTERNATIONAL
STANDARD
SERIAL
NUMBER
INDIA

Impact Factor: 8.118

 9940 572 462

 6381 907 438

 ijirset@gmail.com

 www.ijirset.com

IOT Based Intelligent Home by Using Android App

Saurabh Patil¹, Mayur Patil², Shreeshail Patil³, Abhishek Bhakte⁴, Anjum Attar⁵

U.G. Student, Department of Electrical Engineering, NMCOE, Peth, Maharashtra, India¹

U.G. Student, Department of Electrical Engineering, NMCOE, Peth, Maharashtra, India²

U.G. Student, Department of Electrical Engineering, NMCOE, Peth, Maharashtra, India³

U.G. Student, Department of Electrical Engineering, NMCOE, Peth, Maharashtra, India⁴

Associate Professor, Department of Electrical Engineering, NMCOE, Peth, Maharashtra, India⁵

ABSTRACT: The internet of things (IOT) is connecting the devices and tools to the internet network to be controlled by websites and smart phone applications remotely, also, to control tools and instruments by codes and algorithms structures for artificial intelligence issues. In case we want to create advanced systems using python algorithms, Wi-Fi or Ethernet connection is connected to our tools, equipment, and devices controlling them by smart phone applications or internet websites. That's actually the simplified definition of IoT. Farther than just using the IoT as a smart home to operate lamps or other home-use devices, it can be used as a security system or an industrial-use system, for example, to open or close the main building gate, to operate full automatic industrial machine, or even to control internet and communication ports. And more ideas can be done by using IoT technology. A huge industrial facilities or governmental institutions have much of lamps. Employees sometimes forget to turn them off in the end of the day. This research suggests a solution that can save energy by letting the security to control lighting of the building with his smart home by Blynk application. The lamps can be controlled by switches distributed in the building and Blynk application at the same time with a certain electrical installation. This research presents a simple prototype of smart home, or the easy way and low cost to control loads by Wi-Fi connection generally.

KEYWORDS: IOT, GSM, Speed control, AVR atm328, Thingspeak, CT, PT, Noise, Temperature, Vibration Sensor.

I. INTRODUCTION

A load controlled by computer systems has many advantages compared with manual controlled loads. Nowadays there are many programs and applications help to control things better using codes or python algorithms in artificial intelligence projects. In order to save energy and make loads monitored easily, this research suggests smart home project based on IoT technology. This smart home is an Internet of Things (IoT) project that controls loads with internet connection via Wireless Fidelity WIFI connection. A smart phone connected to internet with Blynk application as a control panel, and NodeMCU microcontroller kit in other side as a controller that receives control commands via WIFI signal. NodeMCU kit is built with ESP8266 WIFI receiver that able to process and analyze WIFI signal to input the microcontroller. The WIFI receiver and microcontroller are built in one kit to be used as IoT project. It's called NodeMCU.

To connect the system to the Internet, needs a WiFi receiver. In my case I used ESP8266 that is connected as built-in in the NodeMCU board that contains a firmware runs with the ESP8266. The firmware is a low-level control computer software.

The NodeMCU is coded via Arduino Integrated Development Environment (IDE) with the Universal Serial Bus port (USB) to tell the NodeMCU what to do, I want to make the NodeMCU controls four-channel relay kit by Blynk hand phone application and shows the temperature that measured by LM35 sensor.

II. LITERATURE SURVEY

Smart Energy Efficient Home Automation System using IOT, by Satyendra K. Vishwakarma, Prashant Upadhyaya, Babita Kumari, Arun Kumar Mishra.

This paper presents a step-by-step procedure of a smart home automation controller. It uses IOT to convert home appliances to smart and intelligent devices, with the help of design control. An energy efficient system is designed that accesses the smart home remotely using IOT connectivity. The proposed system mainly requires, Node MCU as the microcontroller unit, IFTTT to interpret voice commands, Adafruit a library that supports MQTT acts as an MQTT broker and Arduino IDE to code the microcontroller. This multimodal system uses Google Assistant along with a web based application to control the smart home. The smart home is implemented with main controller unit that is connected with the 24-hour available Wi-Fi network. To ensure, that the Wi-Fi connection do not turn off, the main controller is programmed to establish automatic connection with the available network and connected to the auto power backup.

"IOT Based Smart Security and Home Automation", by Shardha Somani, Parikshit Solunke, Shaunak Oke, Parth Medhi, Prof. P. P. Laturkar.

This paper focuses on a system that provides features of Home Automation relying on IOT to operate easily, in addition to that it includes a camera module and provides home security. The android application basically converts Smartphone into a remote for all home appliances. Security is achieved with motion sensors if movement is sensed at the entrance of the house; a notification is sent that contains a photo of house entrance in real time. This notification will be received by the owner of the house via internet such that app can trigger a notification. So owner can raise an alarm in case of any intrusion or he/she can toggle the appliances like opening the door if the person is a guest. The system uses Raspberry Pi, a small sized computer which acts as server for the system. The smart home consist two modules. Home automation that consists; fan light and door controller, and security module that consists; smoke sensor motion sensor and camera module.

"A Dynamic Distributed Energy Management Algorithm of Home Sensor Network for Home Automation System", by Tui-Yi Yang, Chu-Sing Yang, Tien-Wen Sung.

This paper proposes an optimization of home power consumption based on PLC (Power Line Communication) for an easy to access home energy consumption. This also proposes a Zigbee and PLC based renewable energy gateway to monitor the energy generation of renewable energies. ACS and DDEM algorithm are proposed for the design of an intelligent distribution of power management system to make sure ongoing power supply of home networks. To provide efficient power management the power supply models of home sensor network are classified groups viz. main supply only, main supply and backup battery, rechargeable battery power and non-rechargeable battery power. Devices with particular features are assigned to these groups. It targets to establish real time processing scheme to address variable sensor network topologies.

"Enhance Smart Home Automation System based on Internet of Things", by Tushar Churasia and Prashant Kumar Jain.

This paper proposes a system that develops a model to reduce the computation overhead in existing smart home solutions that uses various encryption technologies like AES, ECHD, hybrid, etc. these solutions use intermediate gateway for connecting various sensor devices. The proposed model provides a method for automation with sensor based learning. The system uses temperature sensor for development but other sensors can also be used as per requirement. These smart home devices with sensors can configure themselves autonomously and can operate without human intervention. This work minimizes encryption decryption and focuses on authentication and automation of smart home devices with learning. The system bypasses local gateway mentioned in existing system to provide better security for smart home devices and sensor data and save computation overhead. The real time broker cloud is directly connected with smart home and manages all incoming and outgoing request between users and devices. The main purpose to use real time broker cloud is save time of cryptographic operations.

"Visual Machine Intelligence for Home Automation", by Suraj, Ish Kool, Dharmendra Kumar, Shovan Barman.

The paper present a vision-based machine intelligence system to sense on/off state of common home appliance. The proposed method of sensing the state of appliances results on a novel home automation system. The accessibility of the suite of devices in the home over a remote network is facilitated by the IP Addressing methods in the IOT. This project uses two boards viz. Raspberry Pi and Intel Galileo Gen 2. The communication between the User devices, Raspberry Pi

and the Intel Galileo boards happens over a wireless network. The UDP protocol is deployed to facilitate the wireless communication of the nodes present in the home automation network. A Pi Cam and a USB Logitech camera attached to the rotating shaft of two different servo motor capture snapshots that are passed as inputs to the Machine Learning based models trained using dlib-C++ to detect the state of the operation of the appliances. The proposed method uses visual modality to automate the appliances, as privacy concerns may emerge while using the images from some specific places, as a counter to this issue, an SPDT switch is added to the Raspberry Pi which when turned off ensures that even if the images are taken from the webcams, they are just passed as inputs to the machine learning models and are not displayed on the website when the users access the website on the server address obtained from Raspberry Pi.

III. PROPOSED WORK

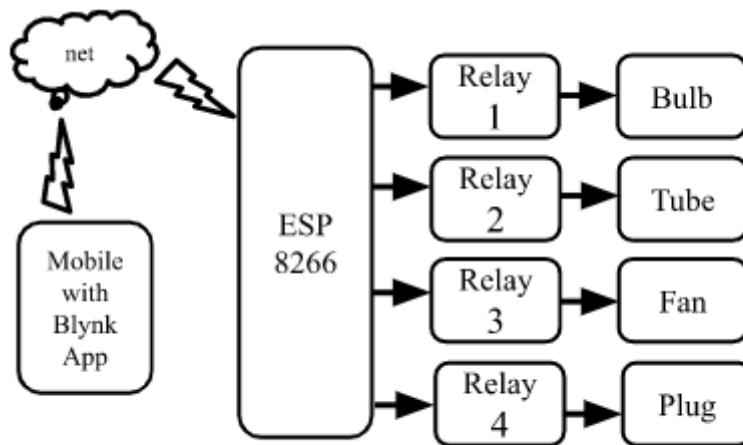

Fig. Block Diagram

The system is based on NodeMCU board as an internet of things system. The NodeMCU is connected to the internet from the hotspot of the smart phone via WIFI connection as the NodeMCU has ESP8266 circuit to connect with the internet. NodeMCU to be connected to the hotspot of the smart phone, needs to be identified to the name of hotspot, the password and token code letting the server of Blynk connects them together. You may need the computer once to transfer code from Arduino IDE to the NodeMCU kit to prepare the software part of the project. Figure 1 shows that the server of Blynk application will process the smartphone-NodeMCU connection. Blynk libraries are ZIP files can be downloaded from Github website to be imported to the Arduino IDE library.

Blynk server will check for internet connection, NodeMCU with android hotspot, the NodeMCU code includes the token code, the name of hotspot and it's password. The information included to the code must be match with the hotspot information to allow ESP8266 connect with the WIFI to be as a channel to exchange commands between smart phone and NodeMCU. Remaining processes are just commands sent from Blynk application to NodeMCU to control loads those are connected to the relay kit as shown in Figure 2. And sensor output value is sent reverse to the Blynk application from NodeMCU kit.

ESP8266 CONTROL RELAY WITH BLYNK APP –

If the ESP8266 is connected with Wi-Fi, then we could control the relay module with Blynk App. We could control, monitor the current status of the relays from anywhere in the world from the Blynk App. When the internet comes back, the ESP32 will fetch the previous state of the switches from the Blynk IoT server and accordingly turn on and off the relays.

CONTROL RELAYS WITH SWITCHES OR PUSH BUTTONS –

We could also manually control the appliances from the switches. If the ESP8266 connected with Wi-Fi then it will send real-time feedback to the Blynk server.

MAX 232:

We are using MAX 232 for serial communication with the components that are Wi-Fi module. MAX232 is used to provide TTL to the components as per the requirement. GSM needs TTL so it is connected to Arduino through MAX232. Some Wi-Fi module doesn't require TTL because it's already build in it and some may require based on its working.

WiFi MODULE (ESP8266):

Wi-Fi stands for Wireless Fidelity. We are using Wi-Fi which acts as heart for IoT. Through Wi-Fi the consumer can set changes in threshold value, he can ON and OFF the electric use. Time to time the readings of units and cost are displayed on blynk app. Consumer can accesses the Arduino board and smart switch with help of Wi-Fi.

DRIVER CIRCUIT (moc3071):

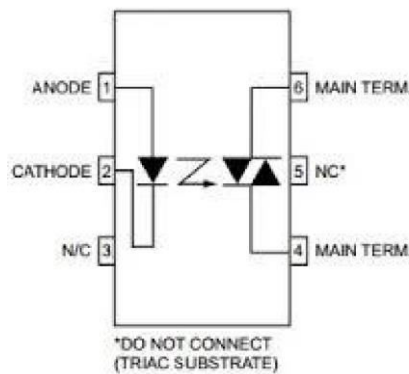

- It is a 6 pin device known as opto coupler or opto isolator.
- In our project we are using this opto coupler to cut off the AC load.
- It is connected to the SSR to cut off the AC load.

SWITCHING DEVICE:

In our system we are using SSR as switching device even though we can use RELAY because SSR is highly advantageous. We are using switching device to switch the energy meter. For ON and OFF purpose of meter we are using switching block. SSR stands for SOLID STATE RELAY.

Why SSR instead of RELAY?

- Both are used as AC switching device, but if switching speed is high than SSR is suitable, if switching speed is slow than RELAY is used.
- Relay life decreases as number of usage time increases, but in SSR there is no change.
- For driving RELAY, current or power required is more comparatively to SSR.
- For switching SSR requires 15amp, whereas RELAY needs (30amp,50amp,90amp) as per requirement.

IV. CONCLUSION

In this proposed work, an internet based smart home system that can be controlled upon user authentication. is proposed and implemented. The home automation using iot has experimentally proven to work by connecting effortless appliances to it. The designed system instigates a process according to the user's. requirements. The android based smart home app communicates with ESP8266 with Blynk app and manual control relays.



REFERENCES

1. “Smart Energy Efficient Home Automation System using IOT”, by Satyendra K. Vishwakarma, Prashant Upadhyaya, Babita Kumari, Arun Kumar Mishra.
2. “IOT Based Smart Security and Home Automation”, by Shardha Somani, Parikshit Solunke, Shaunak Oke, Parth Medhi, Prof. P. P. Laturkar.
3. “A Dynamic Distributed Energy Management Algorithm of Home Sensor Network for Home Automation System”, by Tui-Yi Yang, Chu-Sing Yang, Tien-Wen Sung; in 2016 Third International Conference on Computing Measurement Control and Sensor Network.
4. “Enhance Smart Home Automation System based on Internet of Things”, by Tushar Churasia and Prashant Kumar Jain; in Proceedings of the Third International Conference on I-SMAC (IoT in Social, Mobile, Analytics and Cloud) (I-SMAC 2019) IEEE Xplore Part Number:CFP19OSV-ART; ISBN:978-1-7281-4365-1.
5. “Visual Machine Intelligence for Home Automation”, by Suraj, Ish Kool, Dharmendra Kumar, Shovan Barman.
6. “A Low Cost Home Automation System Using Wi-Fi based Wireless Sensor Network Incorporating internet of Things”, by Vikram.N, Harish.K.S, Nihaal.M.S, Raksha Umesh, Shetty Aashik Ashok Kumar; in 2017 IEEE 7th International Advance Computing Conference.
7. “Voice Controlled Home Automation System using Natural Language Processing and Internet of Things”, by Mrs. Paul Jasmin Rani, Jason Bakthakumar, Praveen Kumaar.B, Praveen Kumaar.U, Santhosh Kumar; in 2017 Third International Conference on Science Technology Engineering & Management (ICONSTEM).
8. Wikipedia(2009). HomeAutomation. From https://en.wikipedia.org/wiki/Home_automation.
9. Theory of IOT from :<https://internetofthingsagenda.techtarget.com/definition/Internet-of-Things-IoT>.
10. About Node MCU from: <https://lastminuteengineers.com/esp8266-nodemcu-arduino-tutorial>.



INNO SPACE
SJIF Scientific Journal Impact Factor
Impact Factor: 8.118



ISSN INTERNATIONAL
STANDARD
SERIAL
NUMBER
INDIA



INTERNATIONAL JOURNAL OF INNOVATIVE RESEARCH

IN SCIENCE | ENGINEERING | TECHNOLOGY

 **9940 572 462**  **6381 907 438**  **ijirset@gmail.com**



www.ijirset.com

Scan to save the contact details