



e-ISSN: 2319-8753 | p-ISSN: 2347-6710

IJRSET

International Journal of Innovative Research in
SCIENCE | ENGINEERING | TECHNOLOGY

INTERNATIONAL JOURNAL OF INNOVATIVE RESEARCH

IN SCIENCE | ENGINEERING | TECHNOLOGY

Volume 13, Issue 4, April 2024

ISSN INTERNATIONAL
STANDARD
SERIAL
NUMBER
INDIA

Impact Factor: 8.423

9940 572 462

6381 907 438

ijirset@gmail.com

www.ijirset.com

RFID Technology for Device Control and Authentication in Industries

Ms.R.Jeeva Rekha¹, P.Gokul², N.Gokulakannan³, R.Jayasurya⁴

Assistant Professor, Department of Electronics and Communication Engineering, Muthayammal Engineering College, Rasipuram, Namakkal(D.t), Tamil Nadu, India. ¹

UG Student, Department of Electronics and Communication Engineering, Muthayammal Engineering College, Rasipuram, Namakkal(D.t), Tamil Nadu, India. ^{2,3,4}

ABSTRACT : The system accomplishes the necessary job by combining RFID technology with biometrics. When a number is detected by the RFID reader at the hostel's entry, the system takes the user's picture and searches the database for a match. Access is allowed when both cards and the recorded picture correspond to a registered user; otherwise, the system activates the alarm and sends an emergency call to the security van via GSM modem. Suspect individuals may be apprehended in this manner. To combat the security risks that many companies are facing these days, an automatic identity and access control system has become essential. Only authorized people will be able to enter the organization once the system is installed at the entrance.

KEYWORDS : Access Control, Smart Building Security, unauthorized Access, RFID Tag Detection.

I. INTRODUCTION

Radio Frequency Identification or RFID is a specific type of radio technology that uses radio waves to identify tags attached to an object and thus identify the object. The tag contains a transceiver chip which is triggered by the electromagnetic wave from the RFID reader and transmits an identification number back to the reader. The identification number is then used for the inventory of the objects with tags. Tags can be passive or active. Passive tags are only powered by the incident electromagnetic wave from the reader and thus have a shorter operating range. Active tags are powered by a battery and can have greater range, up to hundreds of meters. The technology has continued to improve over the years, and the cost of implementing and using an RFID system has continued to decrease, making RFID a cost-effective and efficient alternative to conventional optical scanning. Standard specifications have been developed for RFID technology, addressing security and privacy concerns. Such standards use on-chip cryptography methods for untraceability and tag and reader authentication using digital signature data. RFID (Radio Frequency Identification) is a form of wireless communication that incorporates the use of electromagnetic or electrostatic coupling in the radio frequency portion of the electromagnetic spectrum to uniquely identify an object, animal or person.

Mobile handheld RFID reader and fixed RFID reader. ZEBRA TECHNOLOGIES RFID readers can be fixed (left) or mobile (right). There are three main types of RFID systems: low frequency (LF), high frequency (HF) and ultra-high frequency (UHF). Microwave RFID is also available. Frequencies vary greatly by country and region.

II. REVIEW OF LITERATURE

Design and Implementation of Microcontroller Based Anti-Theft Vehicle Security System using GPS, GSM and RFID, Abu Taher Noman; Samzad Hossain; Shariful Islam; 2018

Stealing the vehicle is the major threat to car or vehicle owners. Nowadays, it is increasing day by day. If not recovered soon, stolen vehicle are generally sold, revamped or even burned, if the resale price is considered to be too low. When a vehicle is stolen, it becomes hard to locate and track it, which considerably decreases the chances of recovering it. An Anti-Theft vehicle security has been developed to mitigate this problem. This system consists of a PIC16F876A microcontroller, fingerprint, RFID, GPS- GSM modules and a tilt sensor. The car will be started with RFID or fingerprint or password. If an unauthorized person wants to open the door of the vehicle, it will

ask for correct RFID or password or fingerprint. The tilt sensor is used to measure any breaking of windows or doors and movement of the vehicle, a message will be sent to the owner's mobile containing the location of the car via GPS-GSM module.

RFID based Access Control and Registration System, Osman Abd Allah; Suliman Abdalla; Marwa Mekki; Alaa Awadallah, 2018

In this paper a user identification system is developed using an RFID technology for registering, monitoring and control of an access pass for security purpose. The system is designed for use in Sudan Atomic Energy Commission premises which helps the managers in monitoring and registers the information to retrieve it in need. The proposed system consists of a control circuit that control a gate entrance, and software which monitors, displays and record user information and system status. The software is capable of reading and displaying the user card number, user name, arrival time, and the number of times the card used and save all these data in a text file in a GUI designed and configured using Lab View software. The system makes a special pass for VIP users to access the system at any time. The control circuit is attached with a GSM modem module that can send an SMS message to a master control mobile phone in case of intruders or unauthorized access. The system performance shows an authenticated and effective data records for the long term periods as a monitored registering system.

III. EXISTING METHOD

Most of these existing works show how RL has been effectively applied to Micro Edge Computing based networks due to network dynamics. Random task generation and arrival exist for a mobile device since independent possibly sensed, collected, and generated by multiple types of applications stochastically. The existing DRL algorithms in terms of convergence, stability, and robustness, proposed a multi agent DRL-based cooperative computation offloading policy in the NOMA enabled MEC system with the aid of expert strategies, scatter networks, and hierarchical agents.

IV. RELATED STUDIES

4.1 RFID Technology and Its Adoption:

As explored in RFID adoption is influenced by social issues competitive pressure and technology competence. The determinants that influenced the promotion of RFID in the healthcare sector include ease of use, usefulness, advantage, government policy, management support and security concerns Adhiarna et al. Proposed a framework for RFID adoption that gives importance to scale, stage and scope. The scale includes organization, industry, and country. Stage contains preliminary, intermediate and mature while scope includes strategy, technology, organization, people, and environment.

4.2 RFID Applications:

Azevedo et al. employed RFID technology to Supply Chain Management related to fashion (FSCM). They used RFID for leveraging logistics functionality, product quality. Tracking or products and making the FSCM system more responsive. The problem they encountered is interoperability. Similarly, Chan and Chong studied the usage of RFID in mobile SM. With respect to supply chains, trust acts as a catalyst for integration RFID. Wamba et al. explored different healthcare applications that are RFID enabled. Asset management and remote healthcare are two important observations enabled by RFID. Beheshti et al. studied the implementation of ERP with RFID technology found that it plays a vital role in future.

4.3 RFID for Security:

Security risks in RFID systems are explored in the risks include entity security risk caused by interference, theft, flaws in protocols and Point of Sale (POS) security risk caused in authentication module, and Business Information System (BIS) security risk caused by storage and audit mechanisms. Baldini et al. studied RFID for securing disaster supply chains.

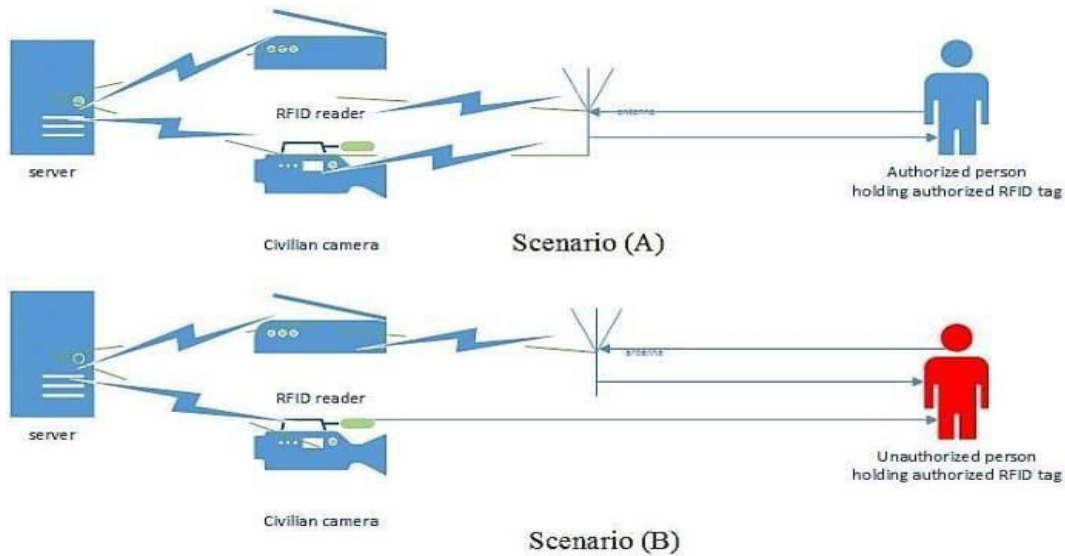

Figure 1 Network Security

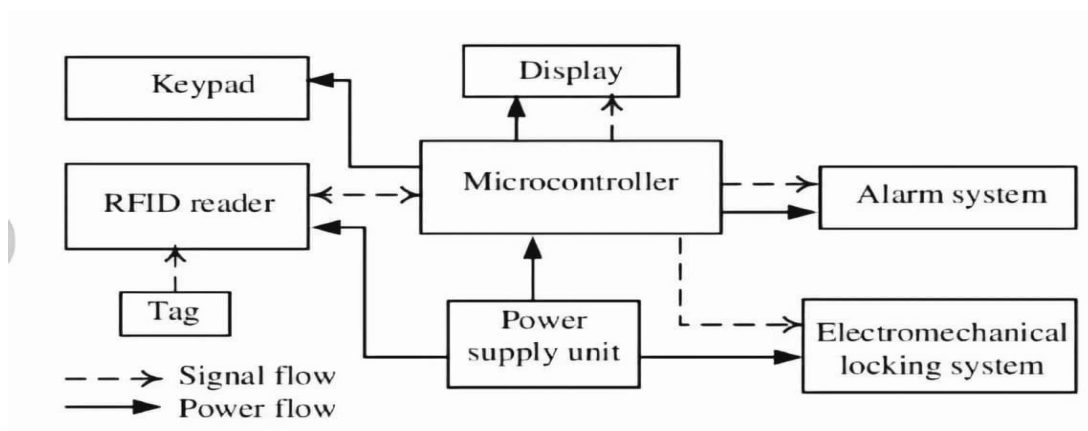

Figure 2 Prototype of Proposed system

V. PROPOSED METHOD

The system was implemented in a microcontroller since this architecture is more appropriate for places as access gates and watches. It was also developed a data encoding in order to saves pace in storage memory. To ensure the correct functioning of system, it was developed a prototype using a RFID reader and tags. Radio frequency identification system (RFID) is an automatic technology and aids machines or computers to identify objects, record metadata or control individual target through radio waves.

5.1 BLOCK DIAGRAM

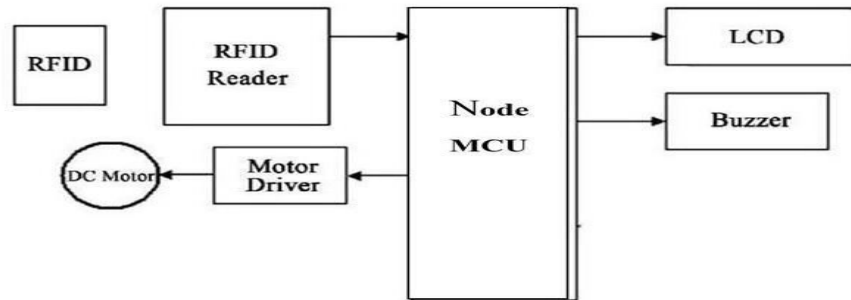

Figure 3: Block Diagram

VI. RESULT AND DISCUSSION

RFID (radio-frequency identification) is a technology that utilizes magnetic waves to identify and track tags attached to items. A radio transponder, a radio receiver, and an emitter make up an RFID system. The tag sends digital data, typically an identifying inventory number, back to the reader when activated by an electromagnetic interrogation pulse from a nearby RFID reader device. The RFID reader's probing radio waves provide energy to passive tags. Because active tags are battery-powered, they can be read from a longer distance from the RFID scanner, up to hundreds of meters.

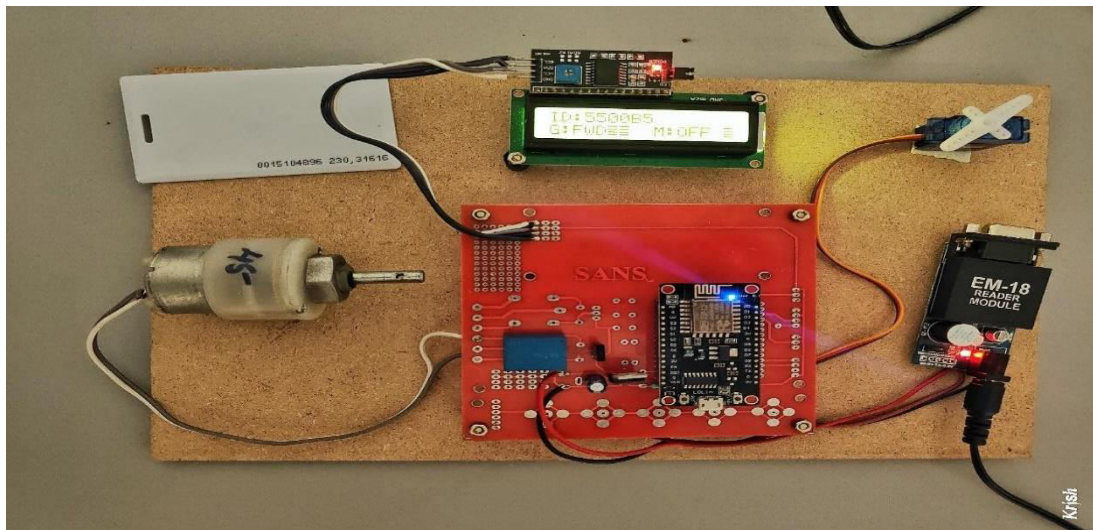

Figure 4: Hardware Implementation of RFID Technology For Device Control And Authentication In Industries

VII. CONCLUSION

A security and access control system for usage in dormitories is described in this article. To distinguish between legitimate and invalid users, the system employs radio frequency identification and biometrics technologies. The system processes data from sub-controllers to complete the security and access control job. Entry monitoring controllers, exit monitoring controllers, and mess monitoring controllers are placed at the appropriate entrance gate, exit gate, and mess gate. These controllers scan the user's RFID tag and look up the number in non-volatile RAM. The controller the computer terminal to capture the use picture after a successful match. The computer system verifies the user's identity using a neural network trained facial recognition module and replies to the controllers by sending the ma "access allowed" or "access refused" message. Controller see the give the user access or make an emergency call as needed. A web server is used to make this system centralized.

REFERENCES

1. Systematic Mapping Study on RFID Technology Achraf Haibi; Kenza Oufaska; Khalid El Yassini; -2022.
2. An overview of RFID Based Security and Access Control System, Bhojraj Agarwal, Assistant Professor -2018.
3. RFID based Access Control and Registration System, Osman Abd Allah; Suliman Abdalla; Marwa Mekki; Alaa Awadallah -2018.
4. RFID and GSM Based Three Level Security System Ankush Vishwanath; Basappa Yellappa Haibatti; Pavan Krishna Kotekar; T.S. Rakesh Kumar.Design and Implementation of Microcontroller Based Anti-Theft Vehicle Security System using GPS, GSM and RFID, Abu Taher Noman; Samzad Hossain;Shariful Islam;-2018.
5. Alwadi, A. Gawanmeh, S. Parvin, and J. N. Al-Karaki, "Smart solutions for RFID based inventory management systems: A survey," Scalable Comput., 2017.
6. Yee-Loong Chong, M. J. Liu, J. Luo, and O. Keng-Boon, "Predicting RFID adoption in healthcare supply chain from the perspectives of users," Econ., 2015.
7. S. D. Verifier and A. H. Drive, "Simulink @ Verification and Validation TM Reference," Re Vision, 2015.
8. D. L. Wu, Wing W. Y. NG, Patrick P. K. Chan, H. L. Ding, B. Z. Jing, and D.S. Yeung, "Access control by RFID and face recognition based on neural network,"
9. N. Chilamkurti, S. Zeadally, and H. Chaouchi, Next-Generation Wireless Technologies (4G and beyond). 2013.
10. N. Ahmad, S. Butler, and U. Ramachandran, "GuardianAngel: An RFID based indoor guidance and monitoring system," 2010, pp.546- 551.
11. L. Wu, Wing W. Y. NG, D. S. Yeung, and H. L. Ding, "A brief survey on current RFID applications," in Proc. International Conference on Machine Learning and Cybernetics, Baoding, July 12-15, 2009, pp. 2330- 2334.



INTERNATIONAL
STANDARD
SERIAL
NUMBER
INDIA



INTERNATIONAL JOURNAL OF INNOVATIVE RESEARCH

IN SCIENCE | ENGINEERING | TECHNOLOGY

 9940 572 462  6381 907 438  ijirset@gmail.com



www.ijirset.com

Scan to save the contact details