



e-ISSN: 2319-8753 | p-ISSN: 2347-6710

IJRSET

International Journal of Innovative Research in
SCIENCE | ENGINEERING | TECHNOLOGY



INTERNATIONAL JOURNAL OF INNOVATIVE RESEARCH

IN SCIENCE | ENGINEERING | TECHNOLOGY

Volume 13, Issue 3, March 2024

ISSN INTERNATIONAL
STANDARD
SERIAL
NUMBER
INDIA

Impact Factor: 8.423

Transformative Disaster Identification from Social Media Posts: Employing Deep Attentive Multimodal Learning

HasthiTeja¹, R.Yaminipoojitha², A. Sai Narayana³, C. Sai Sarath Reddy⁴, K. Roja⁵

¹Assistant Professor, Department of AI, Annamacharya Institute of Technology and Sciences, Tirupati, India

^{2, 3, 4, 5}Student, Department of AI, Annamacharya Institute of Technology and Sciences, Tirupati, India

ABSTRACT: Microblogging platforms like Twitter have become vital for sharing critical information during disasters, both natural and human-caused. Users often post pictures and videos to communicate key details like casualty numbers, infrastructure damage, and immediate needs of those affected. This data is valuable for aid organizations to organize prompt relief efforts. However, sifting through numerous posts to find useful disaster-related information is challenging, calling for an automated system. Prior research showed benefits of integrating text and images for disaster identification, but mostly focused only on text or used basic RNN or CNN models, potentially decreasing performance with long inputs. This project presents a combined disaster identification system using both visual(emojis) and textual data. It utilizes impactful word features and incorporates visual features to categorize tweets. A BiLSTM network with attention finds textual features and visual features. A feature fusion method combines all features before a SoftMax classifier is applied. Evaluation shows the proposed multimodal system outperforms comparison models, demonstrating improved efficiency in identifying disaster information.

KEYWORDS: Microblogging, Social Media, disaster, Tweets, BiLSTM

I. INTRODUCTION

Social media platforms play a critical role in spreading large volumes of important information during disaster events like earthquakes, floods, and hurricanes [1]-[3]. People often use these platforms to communicate at different levels, such as individual to individual, individual to government, individual to community, and government to people [2], [3]. Victims frequently share information about disasters on Twitter, like reporting injuries, deaths, and infrastructure damage. Affected people also request urgent aid by posting images, tweets, and videos. Analysing these social media posts and extracting actionable insights in real-time can greatly assist humanitarian organizations in helping affected people [4]. However, manually analysing and extracting actionable information from the huge number of crisis-related tweets is extremely difficult and time-consuming. To address this challenge, the humanitarian computing community has attempted to develop automated systems for extracting actionable information from disaster-related social media data.

For example, researchers have developed classifiers to identify event types (e.g., flood, hurricane), determine if a post is informative or not, and detect humanitarian information types (e.g., damage types). However, existing works have two main limitations. First, most works on extracting damage or disaster response information from social media posts have focused on textual or image content analysis separately. However, recent studies suggest analysing both texts and images often provides more valuable insights about an event compared to learning from a single modality. Second, the few works utilizing multimodal features apply CNN or RNN models for text representation [5], which may not work well for longer sentences. Our goal is to develop an effective computational model for identifying disaster-related information by synergistically integrating visual and textual features. Specifically, we extract image features using a pre-trained visual (ResNet50) model and textual feature using an attention-based BiLSTM network to address long-range dependency limitations of RNNs and CNNs. We aggregate both feature types via deep-level fusion, followed by a SoftMax layer for classification. We perform extensive experiments on a multimodal damage dataset, where the goal is to classify damage type (e.g., fire, flood, infrastructure damage) from an image-tweet pair.

II. RECENT WORK

According to [6], Twitter's retweeting feature has made it one of the most crucial social media sites for disseminating emergency information in times of crisis. Few research, meanwhile, have looked at how Twitter's capabilities can

facilitate distinct communication patterns that emerge throughout different stages of a crisis. Based on disaster communication literature and Media Synchronicity Theory, we identify distinct disaster phases and two communication types - crisis communication and risk communication - that happen in those phases. We investigate how Twitter's representational features like words, URLs, hashtags, and hashtag importance influence the average retweet time, and how such effects differ based on disaster communication type. Adding more URLs to tweets boosts the average retweet time more in risk-related tweets than in crisis-related tweets, according to our research of tweets from the 2013 Colorado floods. Including key disaster hashtags contributed to faster retweets in crisis versus risk-related tweets. According to our research, the impact of Twitter's media capabilities on the rapid distribution of tweets during emergencies may vary depending on the type of communication.

In [7], Emergency medical personnel have difficult circumstances when trying to reach every person impacted by a crisis because of their limited situational awareness. With its massive user base, social media will become a vital forum for verbal communication amid blunders. However, such analysis is not feasible due to the huge volume of posts on social media. For resource response initiatives to be effective, automated extraction of actionable insights from social statistics is essential. Through the algorithmic mining of pertinent records, emergency services can focus their limited resources on essential tasks. To extract useful information from social media posts, a multimodal deep learning architecture is suggested that combines text and imagery analysis for improved accuracy. Test results show promise, confirming that the suggested strategy is useful in supporting emergency response activities.

In [8], The paper highlights multimodal Learning and how It enables the utilization of many data formats, such as text, images, and videos from social media, for disaster relief efforts. It illustrates how crucial it is to develop the modality interface in order to support the humanitarian effort effectively. While most research now in existence focuses Just on text data, this paper suggests employing convolutional neural networks to jointly simulate both modalities. By carefully analyzing the shortcomings of the real-time multimedia data obtained from social media sites and demonstrating that it beat unimodal models in extensive testing on real datasets, this method seeks to improve disaster response

In [9], This paper continues by outlining how social media has become increasingly popular as a source of real-time information during emergencies. It highlights how difficult it is to interpret data, how quickly information is given, and how rare it is to get data statistics like those found in the early phases of a crisis. Starting with neural network ensemble strategies for tweet classification, the research argues that these strategies perform better than the state-of-the-art methods without requiring a lot of feature engineering. Since statistics typically do not become available in the early stages of an event, the technique emphasizes the use of extra-event data to provide a real-world demonstration of the method's effectiveness.

III. PROPOSED WORK

Figure 1 shows our proposed multimodal architecture for disaster identification. The model has two parallel networks: one for visual feature extraction and one for textual feature extraction. A pre-trained convolutional neural network (ResNet50) is used to extract visual features. A BiLSTM model with an attention mechanism extracts textual features from the tweets. After combining the features from the two modalities, a combined representation is created and delivered to a SoftMax layer for classification.

This allows the model to leverage both image and text data from tweets to identify disasters. The key contributions of this paper:

- We propose a multimodal architecture that utilizes ResNet50 and an attention-based BiLSTM recurrent neural network to classify damage-related posts by exploiting both visual and textual information.
- We compare the performance of the proposed model with existing unimodal and multimodal classification techniques.
- We empirically evaluate the proposed model on a benchmark dataset

- Demonstrate how introducing attention enhances system performance through an intrinsic evaluation.

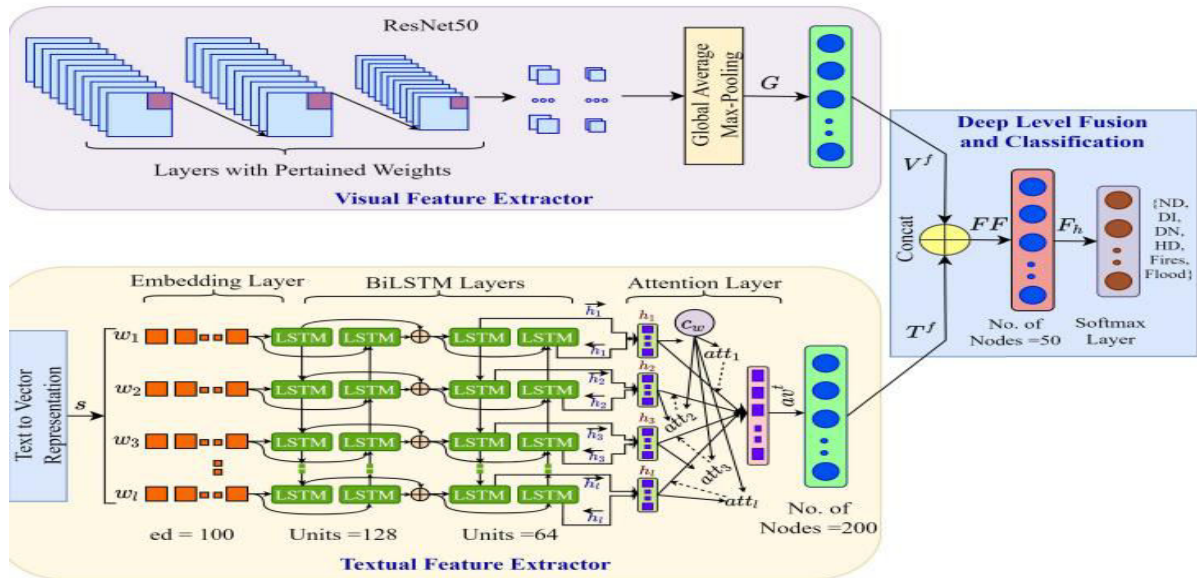

Fig 1.

Proposed Work Architecture

IV. RESULT AND DISCUSSION

To gain a deeper insight into the potential cause behind this impressive achievement, the effectiveness of our suggested method compared to alternative models. we conducted an assessment of performance that was inherent to the subject. In this analysis, our main focus is on examining how the attention layer affects the overall performance of the proposed method. This is done by comparing it with other similar methods between each sub-network is the input size. The text implies that the attention mechanism is not present.

The data points are acquired by performing principal component analysis (PCA) on the extracted concealed features. We notice that the multimodal model lacking attention that There are many similarities that can be observed between the different classes, such as...

"Non-Damage (ND)" refers to situations or events where no physical harm or destruction has occurred. "Damage Infrastructural (DI)" pertains to incidents or conditions that result in harm or destruction of infrastructure.

"DN" stands for "harm Nature (HN)". is trained with a large amount of labelled data, it tends to generalize well to unseen examples. However, if the model is trained with a limited amount of labelled data, it may not perform as well on new examples. Includes the incorporation of the attention layer within the text modality of the model.

As per this work exploration, no significant work has been conducted over the multimodal dataset used in this research except the work done. However, the past study is not exactly comparable with the proposed method due to the differences in evaluation measures and dataset distribution. Therefore, for the comparison, we adopt several recent techniques that have been explored on similar tasks. For uniformity, existing methods have been implemented on the same dataset including the proposed method

V. CONCLUSION

The efficiency of this novel multimodal technique in addressing the issue of recognition of disaster-related materials. From the comprehension of downward evaluation of blunder identification, it perceived that diagnosis of the content was still a challenge using independent modalities. Which gives the impression that certain modalities should be used with the aim of improving the accuracy. Attentions mechanisms by the way were the main enhancement contributor to better performance

Multimodal methods were proven to deliver better performance than their unimodal counterparts. However, there is a potential for further improvement of the presented approach. Future researches will attempt considering the effects of diverse fusion techniques among various modalities with a goal of attaining more comprehensive knowledge. What is

more, multitask performing the operations of diverse tasks related to disaster content processing might become the priority to take the advantage of the relationship between those activities.

Furthermore, it is vital to cope with the demanding situations posed via the dynamic nature of disaster scenarios, in which the content may additionally range considerably in terms of context, severity, and presentation throughout exceptional times. This necessitates the improvement of adaptive fashions able to accommodating diverse and evolving disaster situations. Additionally, the mixing of actual-time records streams and superior sensor technology ought to enrich the multimodal framework, permitting extra well timed and accurate identification of catastrophe-associated content. In addition, considerations pertaining to scalability and aid efficiency should be made in order to guarantee the feasible implementation of the suggested strategy in real-world international contexts. This includes optimization techniques designed to deal with the kind of large-scale datasets and processing limitations that are typically present in disaster management scenarios. Working together with stakeholders and experts in the field will also be crucial to verifying and fine-tuning the suggested method to meet the specific requirements and challenging circumstances of disaster response and mitigation activities.

REFERENCES

- [1] R. Bolle and S. Pankanti, *Personal Identification in Networked Society: Personal Identification in Networked Society*, A. K. Jain, Ed. Norwell, MA, USA: Kluwer, 1998.
- [2] S. Prabhakar, S. Pankanti, and A. K. Jain, "Biometric recognition: Security and privacy concerns," *IEEE Secur. Privacy*, vol. 1, no. 2, pp. 33–42, Mar. 2003.
- [3] N.K. Ratha, "Privacy protection in high security biometrics applications," in *Proc. ICEB (Lecture Notes in Computer Science)*, vol. 6005, A. Kumar and D. Zhang, Eds. New York, NY, USA: Springer, 2010, pp. 62–69.
- [4] K. Nandakumar, A. K. Jain, and S. Pankanti, "Fingerprint-based fuzzy vault: Implementation and performance," *IEEE Trans. Inf. Forensics Security*, vol. 2, no. 4, pp. 744–757, Dec. 2007.
- [5] Z. Erkin, M. Franz, J. Guajardo, S. Katzenbeisser, I. Lagendijk, and T. Toft, "Privacy-preserving face recognition," in *Proc*
- [6] J. Son, H. K. Lee, S. Jin, and J. Lee, "Content features of tweets for effective communication during disasters: A media synchronicity theory perspective," *Int. J. Inf. Manage.*, vol. 45, pp. 56–68, Apr. 2019.
- [7] H. Mouzannar, Y. Rizk, and M. Awad, "Damage identification in social media posts using multimodal deep learning," in *Proc. ISCRAM*, 2018, pp. 1–15.
- [8] F. Ofli, F. Alam, and M. Imran, "Analysis of social media data using multimodal deep learning for disaster response," 2020, arXiv:2004.11838.
- [9] M. Li, B. Liu, Y. Hu, and Y. Wang, "Rapid Classification of Crisis-Related Data on Social Networks using Convolutional Neural Networks," in *25th International Conference on Pattern Recognition*, Milan, Italy, 2021, pp. 5184–5189.



INTERNATIONAL
STANDARD
SERIAL
NUMBER
INDIA



INTERNATIONAL JOURNAL OF INNOVATIVE RESEARCH

IN SCIENCE | ENGINEERING | TECHNOLOGY

 9940 572 462  6381 907 438  ijirset@gmail.com



www.ijirset.com

Scan to save the contact details