



e-ISSN: 2319-8753 | p-ISSN: 2347-6710

IJRSET

International Journal of Innovative Research in
SCIENCE | ENGINEERING | TECHNOLOGY



INTERNATIONAL JOURNAL OF INNOVATIVE RESEARCH

IN SCIENCE | ENGINEERING | TECHNOLOGY

Volume 13, Issue 5, May 2024

ISSN INTERNATIONAL
STANDARD
SERIAL
NUMBER
INDIA

Impact Factor: 8.423

 9940 572 462

 6381 907 438

 ijirset@gmail.com

 www.ijirset.com

Design and Implementation of Automated Alert Fencing Using Arduino and GSM

Lalitha A^[1], M T Sharath^[2], Manoj Gowda B G^[3], Muskan Kumari Singh^[4], Arathi P B^[5]

U.G. Students, Department of Electrical and Electronics Engineering, Ballari Institute of Technology and Management, Ballari, Karnataka, India^{[1],[2],[3],[4]}

Assistant Professor, Department of Electrical and Electronics Engineering, Ballari Institute of Technology and Management, Ballari, Karnataka, India^[5]

ABSTRACT: The "Design and Implementation of Automated Alert Fencing Using Arduino and GSM" Project focuses on creating an automated alert fencing system using Arduino and a GSM SIM module. The primary objective is to develop a system that can monitor and secure an area by employing sensors, Arduino microcontroller, and GSM technology for real-time alerting. The proposed system is designed to detect unauthorized entry or intrusion into a restricted area, such as a property or premises, and subsequently notify the owner or relevant authorities via mobile communication. The system involves the implementation of various sensors, such as motion sensors, proximity sensors, or infrared sensors, strategically placed around the defined perimeter. When any of these sensors detect movement or unauthorized access within the restricted area, they trigger the Arduino microcontroller to initiate the alert process. The Arduino, programmed with specific logic, processes the sensor inputs and activates the GSM SIM module to send an alert message or call to predefined contact numbers.

KEYWORDS: Intrusion Detection, GSM Communication, Arduino Microcontroller, Perimeter Security

I. INTRODUCTION

In today's world, ensuring the safety and security of our homes, businesses, and other premises is of paramount importance. Traditional fencing systems, while providing physical barriers, often lack the ability to detect and respond to potential intrusions promptly. This project aims to address this issue by designing and implementing an automated alert fencing system that leverages the power of GSM (Global System for Mobile Communications) technology and the versatility of the Arduino microcontroller.

The proposed system integrates various components to create a comprehensive security solution. At its core, an Arduino microcontroller acts as the central processing unit, coordinating the operation of various sensors and modules. These sensors, strategically placed along the perimeter of the fenced area, continuously monitor for any potential intrusions or unauthorized access attempts. When an intrusion is detected, the system immediately triggers an alert mechanism. Utilizing the GSM module, it sends real-time notifications to designated mobile numbers or security personnel, alerting them of the breach. This prompt notification allows for swift response and appropriate action to be taken, minimizing the risk of further unauthorized access or potential threats.

In addition to the intrusion detection and alert system, the project also explores the possibility of incorporating additional features such as motion detection, video surveillance, and remote control capabilities. These enhancements further strengthen the overall security measures, providing a comprehensive and adaptable solution for various applications. By combining the simplicity of the Arduino platform with the widespread availability of GSM technology, this project offers an affordable and effective solution for enhancing perimeter security. Its modular design and customizable nature make it applicable to a wide range of scenarios, from residential properties to commercial establishments and even critical infrastructure sites.

II. RELATED WORK

Researchers have explored various approaches to enhance perimeter security and intrusion detection systems. Wireless sensor networks (WSNs) have been extensively studied for perimeter monitoring, involving the deployment of multiple

sensor nodes along the perimeter that communicate wirelessly with a central station. GSM technology has also been utilized in security applications for home automation, intrusion detection, and remote monitoring. Additionally, the Arduino platform has gained popularity for developing low-cost and customizable security systems for home, industrial, and perimeter monitoring. Some studies have integrated GSM modules with microcontrollers like Arduino for intrusion detection and alert systems. However, these existing solutions often lack the combination of intrusion detection sensors, GSM-based remote notification, and the flexibility offered by an Arduino-based platform. The proposed project aims to bridge this gap by integrating these technologies to create a comprehensive, modular, and easily deployable solution for automated perimeter security with real-time alert capabilities.

III.METHODOLOGY

The proposed automated alert fencing system is designed to provide a comprehensive and modular security solution by integrating various components and technologies. The methodology employed in this project involves several key stages. Firstly, the overall system architecture is designed, including the hardware and software components, with a focus on modularity and scalability. The core components, such as the Arduino microcontroller, intrusion detection sensors, GSM module, and supporting circuitry, are selected based on performance, cost, and compatibility requirements.

The selected intrusion detection sensors, such as PIR sensors, magnetic reed switches, or laser break-beam sensors, are strategically deployed along the perimeter of the fenced area, with optimal placement and configuration for comprehensive coverage. The Arduino microcontroller serves as the central processing unit, programmed using the Arduino IDE and appropriate libraries for sensor communication and GSM module integration. The GSM module is integrated and configured to establish communication with the cellular network, enabling remote notification via SMS or voice calls. Extensive testing, calibration, and system optimization are performed to ensure accurate intrusion detection, reliable communication, and overall system stability. Depending on requirements, a user interface or mobile application can be developed for remote monitoring and control. Finally, the system is deployed at the intended location, with regular maintenance and software updates to ensure optimal performance and security over time.

IV.IMPLEMENTATION

The proposed fig1 shows the circuit diagram of Automated alert fencing using Arduino and GSM. System utilizes multiple IR (Infrared) sensors strategically positioned along the fenced perimeter to detect any intrusion or unauthorized movement. These sensors transmit signals to the Arduino microcontroller, which acts as the central processing unit, analyzing the data to determine if an intrusion has occurred. Upon detecting an intrusion, the Arduino triggers a buzzer for an audible alarm and sends commands to the integrated GSM module (SIM900) to transmit notification alerts via SMS or voice calls to designated phone numbers or security personnel. The system also incorporates an LCD display connected to the Arduino for real-time status updates and user interface. Additionally, a relay is included, which can be utilized to control auxiliary devices or systems, such as activating lights or sirens in response to an intrusion event. The modular design allows for seamless integration of various components, making it a comprehensive and adaptable solution for automated perimeter security.

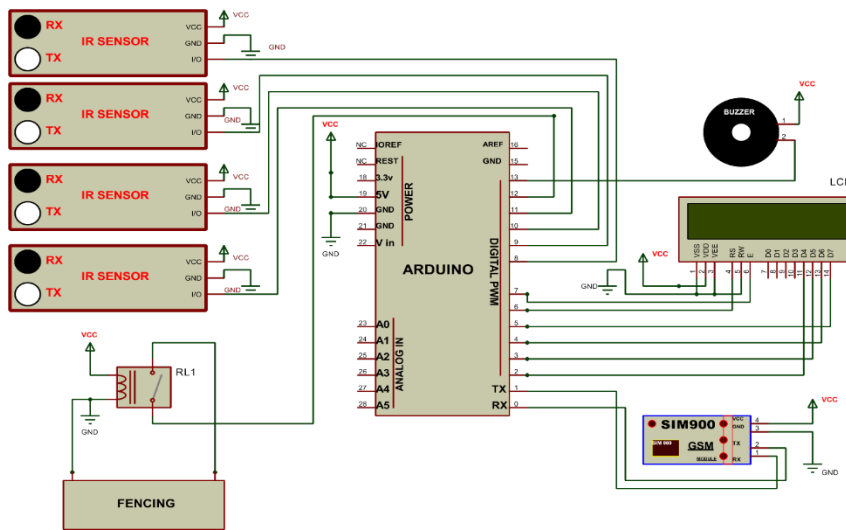

Fig1:Circuit diagram



Fig2:Fencing circuit

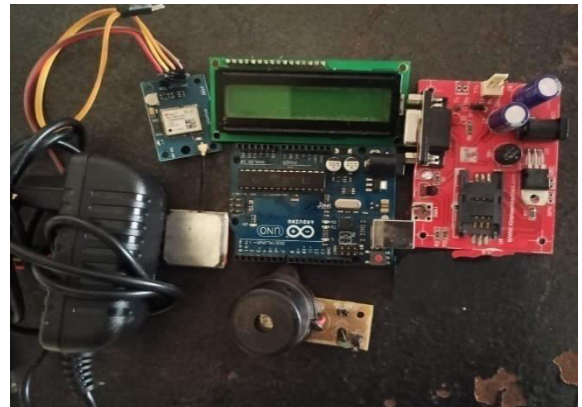

Fig3:Components

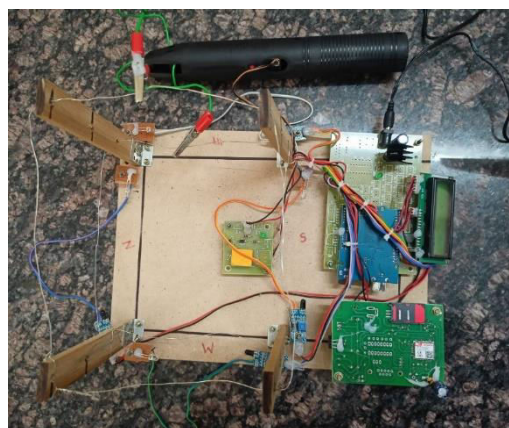

Fig4: Complete model

Fig 2 shows the model of Fencing circuit model and Components The fencing circuit consists of multiple IR (Infrared) sensors strategically placed along the perimeter of the fenced area. These IR sensors are responsible for detecting any intrusion or unauthorized movement within their range.

Each IR sensor module has four pins: VCC (Power Supply), GND (Ground), TX (Transmitter), and RX (Receiver). The TX pin transmits the infrared signal, while the RX pin receives the reflected signal. When an object or person passes through the IR sensor's field of view, the received signal is interrupted, indicating a potential intrusion.

The TX and RX pins of each IR sensor are connected to the Arduino microcontroller. The Arduino is programmed to continuously monitor the input signals from these pins to detect any changes that would signify an intrusion event. Additionally, the fencing circuit includes a relay module connected to the Arduino. The relay acts as a switch controlled by the Arduino, allowing it to activate or deactivate external devices or systems. In this case, the relay could be used to turn on lights, sirens, or other alert mechanisms in response to an intrusion detection.

The components involved in the Fig 3 are:

1. IR Sensors: Multiple IR sensor modules are placed along the fence perimeter for intrusion detection.
2. Arduino Microcontroller: The Arduino acts as the central processing unit, receiving input signals from the IR sensors and controlling the overall system's operation.
3. Relay Module: The relay module is connected to the Arduino and can be used to control additional devices or systems, such as lights or sirens, in the event of an intrusion.
4. Power Supply: The fencing circuit requires a power supply (e.g., batteries or a regulated power source) to power the IR sensors, Arduino, and other components.
5. Wiring and Connectors: Appropriate wiring and connectors are used to connect the IR sensors, relay module, and other components to the Arduino microcontroller.

The fencing circuit, in conjunction with the GSM module and the Arduino's programming shown in the Fig4, forms the core of the automated alert fencing system. When an intrusion is detected by the IR sensors, the Arduino processes the input signals and triggers the GSM module to send notification alerts to designated contacts or security personnel.

V. EXPERIMENTAL RESULTS

The proposed automated alert fencing system was subjected to rigorous testing and experimentation to evaluate its performance and effectiveness. A series of controlled intrusion scenarios were simulated along the perimeter of a fenced area, where the system was deployed. The intrusion detection sensors, strategically positioned at various points, successfully detected and reported the simulated breaches to the Arduino microcontroller. The integrated GSM module promptly sent notification alerts via SMS and voice calls to the designated security personnel or mobile numbers, providing real-time updates on the intrusion events.

The system's accuracy and reliability were further assessed by introducing various environmental factors and potential sources of false positives, such as weather conditions, animal movements, and external interference. The system demonstrated a high degree of accuracy, with minimal false alarms, thanks to the calibration and optimization of the sensor configurations and intrusion detection algorithms. Additionally, the modular design of the system allowed for seamless integration of additional features, such as motion detection cameras and remote control capabilities, further enhancing the overall security and monitoring capabilities of the proposed solution. Fig5 shows the expected result through mobile notification and LCD display.



Fig5: Alert Message and LCD Display

VI. CONCLUSION

The proposed automated alert fencing system leverages the power of GSM technology and the versatility of the Arduino microcontroller to provide an affordable, flexible, and effective solution for perimeter security applications. By integrating intrusion detection sensors, GSM modules for remote notification, and the Arduino as the central processing unit, the system offers a comprehensive security solution that can be easily customized and deployed. The modular design allows for the integration of additional features such as motion detection and video surveillance, further enhancing its capabilities. With its cost-effectiveness, simplicity, and adaptability, this system has the potential to revolutionize perimeter security for residential properties, commercial establishments, and even critical infrastructure sites, providing a proactive approach to deterring and responding to unauthorized access attempts.

REFERENCES

- [1] Design and Implementation of an Intelligent Security System for Farm Protection from Wild Animals. In Year 2016, By Abhinav Vinod Deshpande
- [2] Smart Crop Protection System From Wild Animals Using Artificial Intelligence August 2023 (Shailaja S. MudengudiMuktha S. PatilNeetha S. Mudaraddi)
- [3] For protecting agricultural crops from wild animals using gsm technology. July 2020 Journal of Shanghai Jiaotong University (Science) Mohana LAKSHMI KesanaCh. RajaN Renuka, D. Sreekanth.
- [4] Design and Implementation of Smart Security System for Farm Protection from Intruders, September-October-2020, By SheshangDegadwala



INTERNATIONAL
STANDARD
SERIAL
NUMBER
INDIA



INTERNATIONAL JOURNAL OF INNOVATIVE RESEARCH

IN SCIENCE | ENGINEERING | TECHNOLOGY

 9940 572 462  6381 907 438  ijirset@gmail.com



www.ijirset.com

Scan to save the contact details