

# Comparison of Z Source Inverter with Voltage Source Inverter Feeding Induction Motor

R. Kiranmayi

Associate Professor, Department of EEE, JNTUHCEH, Hyderabad, India

**ABSTRACT:** This paper presents minimization of torque pulsations using Z source inverter (ZSI) compared to voltage source inverter. Z source inverter acts as both buck and boost converter depending on the requirement where as Voltage source inverter has buck characteristics only and current source inverter has boost characteristics only. Using ZSI any desired voltage can be obtained by varying boost factor which varies from zero to infinity. There are several control strategies for ZSI which are based on Pulse Width Modulation (PWM) Technique. They are Simple Boost Control, Maximum Boost Control, Constant Boost Control. Because of the inclusion of Shoot through states, ZSIs are superior to VSIs. The switches used in these inverters are IGBTs as they are self commutating and also have low switching losses. The circuit is simulated using MATLAB/SIMULINK and the results are analyzed.

**KEYWORDS:** Z source inverter(ZSI), voltage source inverter(VSI), converter, switching losses, pulse width modulation technique(PWM) .

## I. INTRODUCTION

There exists two types of traditional inverters namely voltage source (fed) inverters and current source (fed) inverters. Figure1 shows the topology of the voltage source inverter. The input to the inverter is a dc voltage source with a capacitor in parallel to absorb the high frequency ripple. The inverter bridge consists of six switches with a freewheeling diode in parallel with each of them. The voltage source inverter has several limitations like the output voltage range is limited, the inverter cannot output a higher voltage than the dc bus voltage. For many applications, when the input dc voltage is not always constant, like a fuel cell, photovoltaic array, during voltage sag etc, a dc/dc boost converter is often needed to boost the dc voltage to meet the required output voltage. This increases the system complexity and the cost and reduces the system reliability.

The two switches on the same phase leg cannot be gated at the same time, otherwise a short-circuit will occur and destroy the inverter. The mistrigger caused by electromagnetic interference (EMI) is a major killer of the inverter. For safety reasons, there is always a dead time to make sure that the two switches will not be turned on simultaneously. However, the dead time can cause output voltage distortion and harmonic problems. The harmonic problem can be solved by implementing a current/voltage feedback control; however, this increases the system complexity.

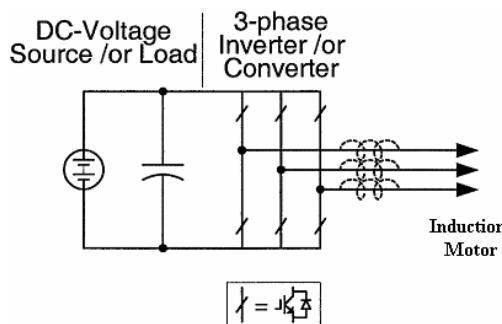

Fig.1 Voltage source inverter

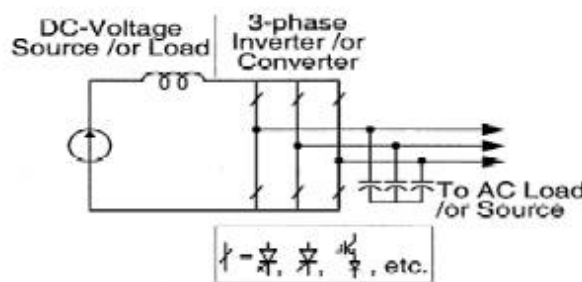

Fig.2 Current source inverter

The current source inverter is shown in figure 2. A dc current source feeds the main converter circuit, a three-phase bridge. The dc current source can be a relatively large dc inductor fed by a voltage source such as a battery, fuel-cell stack, diode rectifier. The inverter bridge consists of six switches with a reverse blocking diode in series or switches with reverse blocking capability. Three capacitors are connected at the ac side of the inverter to provide a leading power factor load. The current source inverter has several limitations like since it a boost converter, for applications where a wide voltage range is required, extra circuitry has to be used to obtain the required voltage. However, this increases the circuit complexity and reduces the efficiency as well as the reliability. At least one switch in the upper three devices and one in the lower three devices has to be turned on at the same time, or an open circuit will occur and destroy the inverter. Mistrigger caused by the EMI noise could significantly reduce the system reliability. To make sure

that there will be no open circuit, overlap time is often needed, which will cause output waveform distortion and low frequency harmonic problem. The switches of the current source converter have to block reverse voltage that requires a series diode to be used in combination with high-speed and high-performance transistors such as insulated gate bipolar transistors (IGBTs).

### II. Z-SOURCE CONVERTER

To overcome problems of the traditional V-source and I-source converters, this paper presents an impedance-source (or impedance-fed) power converter (abbreviated as Z-source converter) and its control method for implementing dc-to-ac, ac-to-dc, ac-to-ac, and dc-to-dc power conversion. Figure 3 shows the general Z-source converter structure proposed. It employs a unique impedance network to couple the converter main circuit to the power source, load, or another converter, for providing unique features that cannot be observed in the traditional V- and I-source converters where a capacitor and inductor are used, respectively. The Z-source converter overcomes the above-mentioned conceptual and theoretical barriers and limitations of the traditional V-source converter and I-source converter and provides a novel power conversion concept.

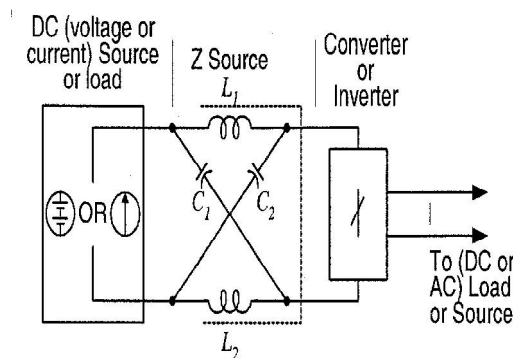

Fig. 3 General structure of the Z-source converter

In figure 3, a two-port network that consists of a split-inductor L1 and L2 and capacitors C1 and C2 connected in X shape is employed to provide an impedance source (Z-source) coupling the converter (or inverter) to the dc source, load, or another converter. The dc source/or load can be either a voltage or a current source/or load. Therefore, the dc source can be a battery, diode rectifier, thyristor converter, fuel cell, an inductor, a capacitor or a combination.

### III. CIRCUIT ANALYSIS AND OBTAINABLE OUTPUT VOLTAGE OF ZSI

Assuming that the inductors and capacitors has the same inductance and capacitance, respectively, the Z-source network becomes symmetrical. From the symmetry and the equivalent circuits

$$\begin{aligned} V_{C1} &= V_{C2} = V_c \\ v_{L1} &= v_{L2} = v_L \end{aligned} \tag{1}$$

Given that the inverter bridge is in the shoot-through zero state during a switching cycle and from the equivalent circuit

$$v_L = V_c \quad v_d = 2V_c \quad v_i = 0 \tag{2}$$

Now consider that the inverter bridge is in one of the eight non shoot-through states for an interval of  $T_0$ , during the switching cycle,  $T$ . From the equivalent circuit

$$v_L = V_o - V_c \quad v_d = V_o \quad v_i = V_c - v_L = 2V_c - V_o \tag{3}$$

where  $V_o$  is the dc source voltage and  $T = T_0 + T_1$ .

The average voltage of the inductors over one switching period ( $T$ ) should be zero in steady state, from (2) and (3), thus

$$V_L = v_L = \frac{T_0 V_c + T_1 (V_o - V_c)}{T} = 0 \tag{4}$$

Or

$$\frac{V_o}{V_c} = \frac{T_1}{T_1 - T_0} \tag{5}$$

Similarly, the average dc-link voltage across the inverter bridge can be found as

$$V_i = v_i = \frac{T_0 \cdot 0 + T_1 (2V_c - V_o)}{T} = \frac{T_1}{T_1 - T_0} V_o = V_c \tag{6}$$

The peak dc-link voltage across the inverter bridge is expressed in (3) and can be rewritten as

$$v_i = V_c - v_L = 2V_c - V_o = \frac{T_1}{T_1 - T_o} V_o = B \cdot V_o \tag{7}$$

where

$$B = \frac{T_1}{T_1 - T_o} = \frac{1}{1 - \frac{T_o}{T}} \geq 1 \tag{8}$$

B is the boost factor resulting from the shoot-through zero state.

The peak dc-link voltage  $v_i$  is the equivalent dc-link voltage of the inverter. On the other side, the output peak phase voltage from the inverter can be expressed as

$$v_{ac} = M \cdot \frac{v_i}{2} \tag{9}$$

where M is the modulation index. Using (7), (9) can be further expressed as

$$v_{ac} = M \cdot B \cdot \frac{V_o}{2} \tag{10}$$

Equation (10) shows that the output voltage can be stepped up and down by choosing an appropriate buck-boost factor  $B_B$ ,

$$B_B = M \cdot B = (0 - \infty) \tag{11}$$

From (1), (5) and (8), the capacitor voltage can be expressed as

$$V_{c1} = V_{c2} = V_c = \frac{1 - \frac{T_o}{T}}{1 - 2\frac{T_o}{T}} V_o \tag{12}$$

#### IV. PULSE WIDTH MODULATION

In PWM method, a fixed dc input voltage is given to the inverter and a controlled ac output is obtained by adjusting the on and off periods of the inverter components. This is the most popular method of controlling the output voltage and this method is termed as Pulse Width Modulation control. PWM inverters are gradually taking the place of other types of inverters in industrial applications. PWM techniques are characterized by constant amplitude pulses. The width of these pulses, however, is modulated to obtain the inverter output voltage control and to reduce its harmonic content.

The distribution of the shoot-through in the switching waveforms of the traditional pulse width modulation concept is the key factor to control the ZSI. The dc-link voltage boost controllable range of ac output voltage. Voltage stress across the switching devices and harmonic profile of the output are purely based on the method of control algorithm adopted to insert the shoot-through. There are control methods which have been presented to control ZSI that include sinusoidal PWM and modified space vector modulation based PWM techniques. In this paper simple boost control (SBC) algorithm is evaluated for different operating modes. The buck-boost operation of the inverter is based on the boost factor, which in turn based on the placement of the shoot-through time period in between the active states. The shoot-through period is carefully inserted before or after the active states by keeping the time period of the active states constant.

Simple boost control uses two straight lines to control the shoot-through states, as shown in figure 4. When the triangular carrier waveform is greater than the upper envelope  $V1$  or lower than the bottom envelope  $V2$ , the circuit turns into shoot-through state. Otherwise it operates just as traditional carrier-based PWM.

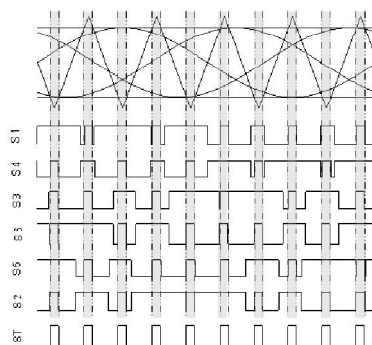

Fig. 4 Modulation using Simple Boost Control

This method is uncomplicated. However, the resulting voltage stress across the device is relatively high because some traditional zero states are not utilized either partially or fully. For a complete switching period,  $T_s$  is total switching period,  $T_o$  is the zero state time period and  $D_o$  is the shoot-through duty ratio ( $D_o = T_o / T_s$ ).

Then the boost factor (B) can be

$$B = \frac{1}{1 - 2D_o} = \frac{1}{1 - 2\frac{T_o}{T_s}}$$

Voltage gain (G) of the inverter can be written as

$$G = \frac{vac}{vdc/2} = ma * B = \frac{ma}{1 - 2D_o}$$

Where *vac* is ac output voltage and *vdc* is input dc voltage.

In order to produce an output voltage that require a high voltage gain, a small modulation index (*ma*) has to be used. However, small modulation index result in greater voltage stress on the devices. When the modulation index is increased, the switching frequency of the inverter also increases and hence the switching losses.

The voltage gain (*G*) of the inverter with simple boost control can be written by

$$G = ma * B = \frac{vac}{vdc/2} = \frac{ma}{2ma - 1}$$

Then the modulation index (*ma*) can be related with the voltage gain of the inverter as

$$ma = \frac{G}{2G - 1}$$

The voltage stress across the power switches is

$$V_s = B * V_o = (2G - 1)V_o$$

The voltage stress across the switches is quite high when simple boost control is used. This characteristic will restrict the obtainable voltage gain because of the limitation of device voltage rating.

### V. SIMULINK MODELS & RESULTS

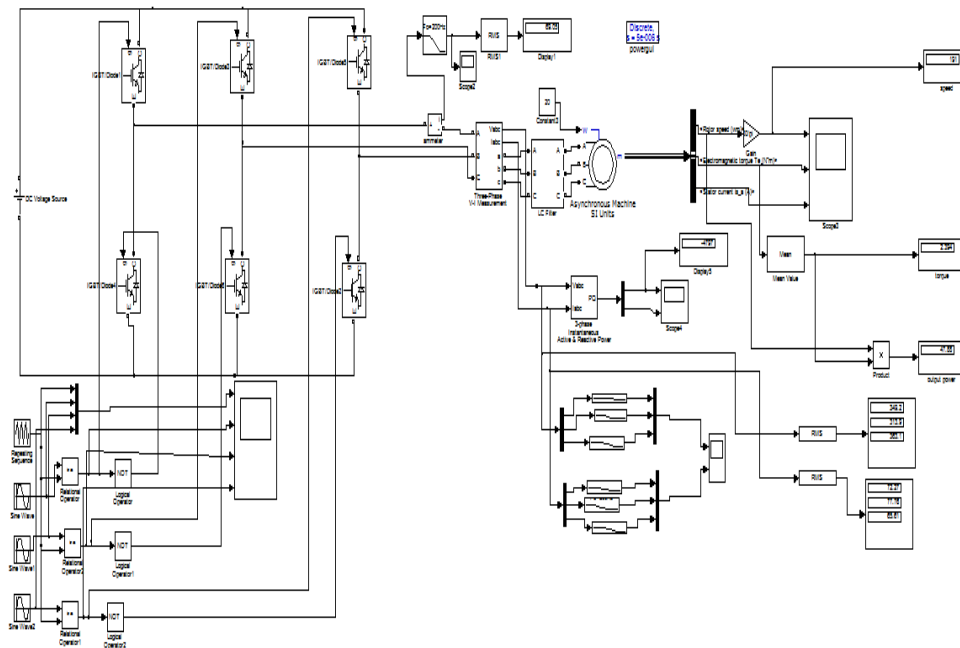

Fig. 5 Simulink model of Induction Motor fed from VSI

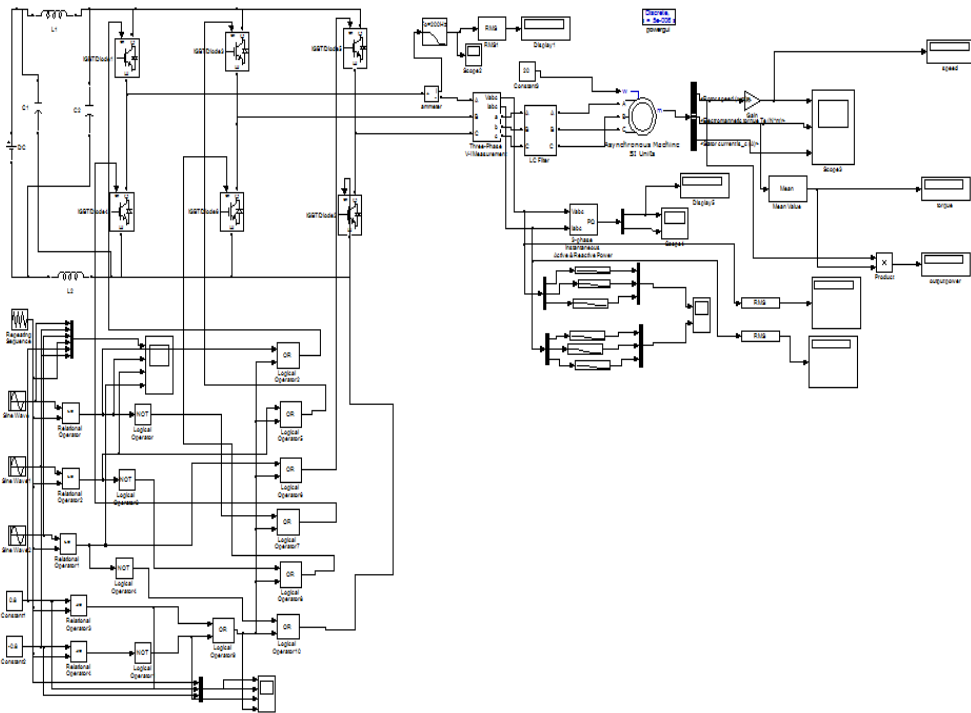

Fig. 6 Simulink model of Induction Motor fed from ZSI

On comparing the output waveforms of induction motor, it can be inferred that the torque pulsations and ripple content in the current are fairly reduced.

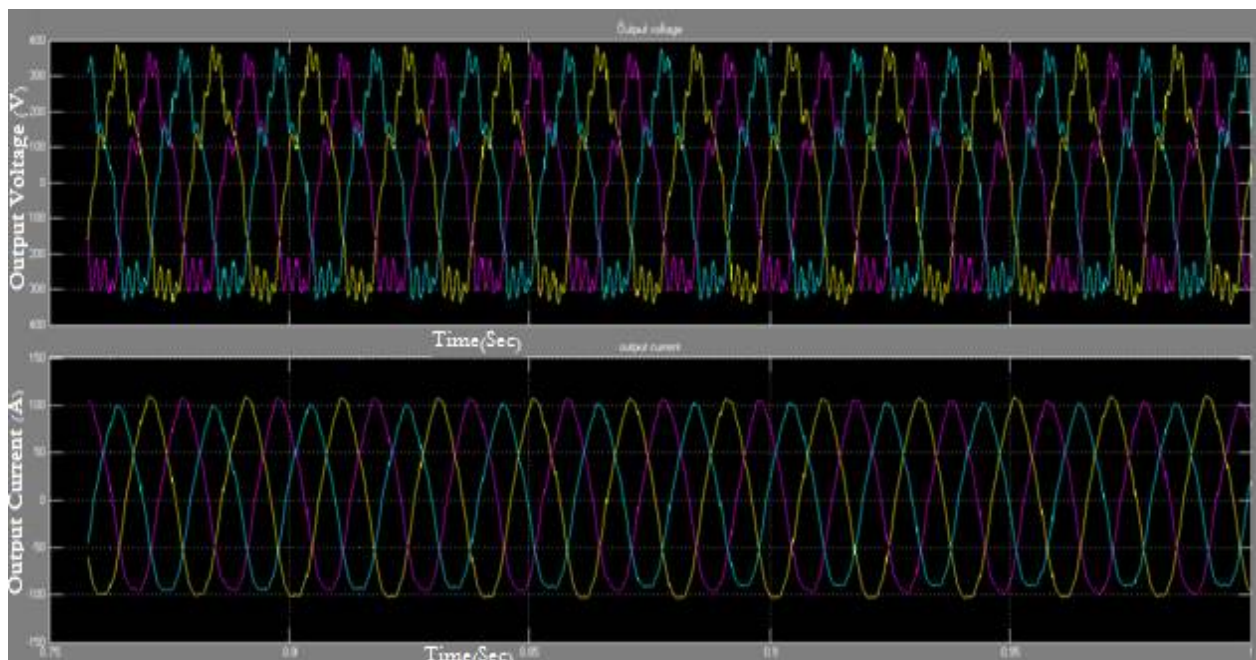

Fig. 7 Output voltage and output current from VSI



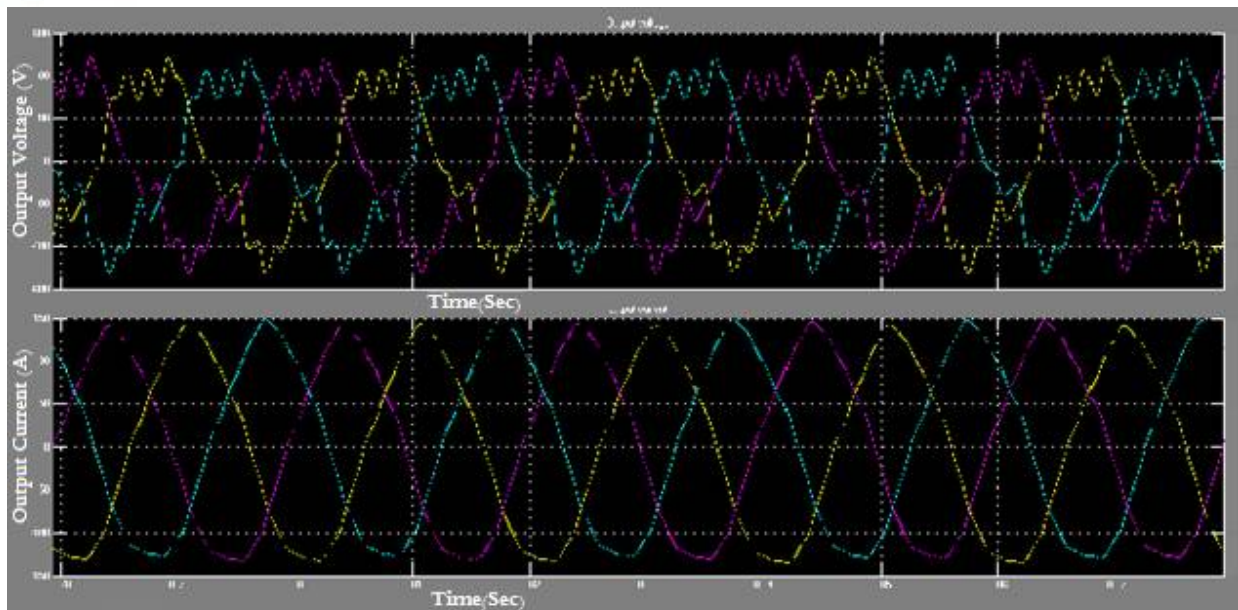

Fig. 8 Output voltage and output current from ZSI

With the same input DC voltage i.e., 100 volts to both the inverters, the output voltage and output current are both boosted up in case of ZSI compared to VSI. The harmonics in the output current are also reduced and almost a sinusoidal wave is obtained. The use of Simple Boost Control Strategy in PWM of ZSI boosts up the output voltage by inserting the shoot through states when compared to normal conventional PWM used in VSI.

## VI. CONCLUSIONS

Compared to the VSI, the ZSI has the following merits:

- Control scheme of ZSI offer new solutions for light commercial and consumer applications.
- The ZSI system can produce an output voltage greater than the ac input voltage by controlling the boost factor, which is not possible for the traditional adjustable speed drive systems.
- A PWM control method was carried out for ZSI fed induction motor drive. The output voltage obtained from ZSI is not limited and can be boosted beyond the limit imposed by conventional VSI.
- The control strategy used in the simulation is Simple Boost Control technique. On comparing the output waveforms, the stator current ripples are reduced.

## REFERENCES

- [1] F. Z. Peng, "Z-source inverter," IEEE Trans. Ind. Applicat., vol. 39, no.2, pp. 504–510, Mar./Apr. 2003.
- [2] F. Z. Peng, X. Yuan, X. Fang, and Z. Qian, "Z-source inverter for adjustable speed drives," IEEE Power Electron. Lett., vol. 1, no. 2, pp. 33–35, Jun. 2003.
- [3] Vinod Kumar Khanna, "Insulated Gate Bipolar Transistor (IGBT): Theory and Design" IEEE Press, Wiley-Interscience.
- [4] AtulKushwaha, Mohd. Arif Khan, AtifIqbal and Zakir Husain, "ZSource Inverter Simulation and Harmonic Study", Global Journal of Advanced Engineering Technologies-Vol1-Issue1-2012.
- [5] B.Y. Husodo, M. Anwari, and S.M. Ayob, "Analysis and Simulations of Z-Source Inverter Control Methods", IEEE Transactions on Industry Applications, vol. 42, pp. 770 – 778, May-Jun 2006.
- [6] P.S.BIMBHRA, Power Electronics.