

# Finite Element Analysis of Induction Furnace for Optimum Heat Transfer

Nihar P Bara

PG Student, Department of Mechanical Engineering, RK University, Rajkot, India

**Abstract:** The heat transfer characteristics of the composite wall of the induction furnace need to be evaluated for the efficient operation. The extrusion industries are keenly involved in improving their efficiency of the induction furnace to melt brass material by performing the modifications in the furnace and have modified the wall thickness of composite without prior computational calculation but purely based on their experience. The objective of the present work is to computationally validate the currently modified composite wall of induction furnace for required heat transfer using Finite Element Method (FEM) considering transient heat conduction and to perform the structural analysis for the determination of thermal stress in different working condition. The objectives are carefully selected to assist the extrusion industries to efficiently use their induction furnace by performing the computation work to fully understand its behaviour with different working condition.

**Keywords:** Induction Process, Thermal Analysis, Heat transfer, Wall thickness.

## I. INTRODUCTION

Induction heating processes have become increasingly used in these last years in industry. The main advantages of using these processes when compared to any other heating process (gas furnace.) are, among others, their fast heating rate, good reproducibility and low energy consumption. The induction heating process basically consists in transmitting by electromagnetic means, energy from a coil through which an alternative current is circulating. Induced currents in the conductive part due to the well-known Foucault law then heat the workpiece thanks to the Joule effect. Induction heating processes are mainly used either at low frequencies (around 50 Hz), usually in order to reach a temperature distribution as uniform as possible within the material before any forming process, or at much higher frequencies (104–106 Hz) in order to heat very locally near the surface, usually for heat treatments[1].

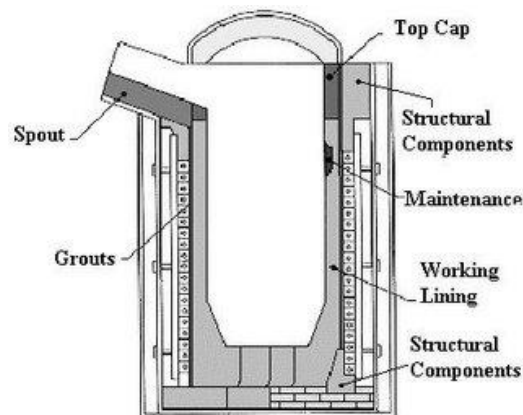

Fig.1 Furnace used in Industries

The basic induction model is shown in the Fig.1. The extrusion industries use the furnace for heating of metal for their processes. The structure of furnace consists of inner space for metal melting, ramming mass for effective heat transfer and induction coil for the supply of heat. The design of induction furnace involves in the proper composition of the composite wall for the proper melting of metals. There are numerical calculations involved in the wall thickness but the industries fit the wall thickness mostly based on experience. Most induction heating processes are set up using engineering experience and a trial-and-error procedure in order to achieve the corresponding goal (grain size control, uniform prescribed temperature, hardness map, etc.). Induction heating process simulation, which couples electromagnetic and heat transfer equations, can be of great help for a more in depth understanding of occurring physical phenomena. So far, various numerical models have been developed coupling electromagnetism and heat transfer. Most models involve the well-known finite element approach or mixed finite element and boundary element approaches.

The recent research papers have been studied carefully and the papers related closely with the present work have been discussed in the subsequent paragraphs. The work related with the induction furnace has been analysed by different researchers in many different ways. The valuable points required for the enlightenment of the analysis is highlighted in this section.

H.k.Jung [2] performed the experimental work in the induction heating process of A356 (ALTHIX) alloy billets of 76 mm diameter and 90 mm length to reduce the temperature gradient of the billet. The optimal reheating conditions to apply the thixoforming process were investigated by changing the reheating time, holding time, holding temperatures, capacity of the induction heating system, and adiabatic material size. This study shows that, the larger the billets size, the better the multi-step reheating, and the heating time and the capacity of the induction heating system must be increased. In case of the three-step reheating process, the final holding time is most important factor and 2 min is suitable to maintain a globular microstructure.

Dae-Cheol Ko et al [3] established an analytical technique in order to investigate the behaviour of semi-solid material considering induction heating of the workpiece. The induction heating process is analysed using the commercial finite element software, ANSYS. The finite element program, SFAC2D, for the simulation of deformation in the semi-solid state was developed. The behaviour of semi-solid material is described by a viscoplastic model for the solid phase and by Darcy's law for the liquid flow. Simple compression and closed-die compression processes considering induction heating are analysed. To validate the effectiveness of the proposed analytical technique, the results of simulation were compared with those of experiment. [4]

Y. Favennec et al. [5] developed a general automatic optimization procedure coupled to a finite element induction heating process simulation. The mathematical model and the numerical methods are presented along with results validating the model. The first part of this paper presents the direct induction heating mathematical model, the related main numerical choices and especially the ultra-weak coupling procedure. The general optimization problem is then presented with the full detailed transposition of the ultra-weak coupling procedure to the adjoint problem. Numerical results provided at the end prove the efficiency and robustness of the adjoint model in optimizing induction heating processes.

Ki Wan Kim et al. [6] performed an inverse boundary analysis of surface radiation in an axisymmetric cylindrical enclosure is conducted in this study. The net energy exchange method was used to calculate the radioactive heat flux on each surface, and a hybrid genetic algorithm was adopted to minimize an objective function, which is expressed by the sum of square errors between estimated and measured or desired heat fluxes on the design surface. They have examined the effects on the estimation accuracy of the measurement error as well as the number of measurement points. Furthermore, the effect of a variation in one boundary condition on the other boundary conditions was also investigated to get the same desired heat flux and temperature distribution on the design surface.

Vivek R. Gandhewar et al. [7] developed a new generation of industrial induction melting furnaces. The practices followed in Induction Furnaces for the development are discussed in this paper. They carried out thorough a literature review account of various practices presently being followed in steel industries using Induction Furnace with a view to gather principal of working. They performed a pilot in few industries in India as well. They have provided some recommendations for the productivity improvement. They proposed that due to non-availability of the proper instrumentations the effect of the ill practices cannot be precisely judged, if this is properly measured, the percentage of productivity improvement in steel melting Induction Furnace can be calculated.

A.Bhatt et al. [8] showed how to solve the induction heating problem in the induction furnace with complex geometry. The results of this study have shown that the temperature of the crucible rises to 1500°C in 2 hours of heating time at frequency of 8 kHz and current of 400 A. Hence these conditions are favourable for melting of copper (melting point = 1085 °C) in the crucible. The studies revealed that copper-liner is effective in reducing the electromagnetic coupling between the coil and the vessel and thus prevents vessel from getting heated up by this effect.

It is observed from the literature that the FEM was primarily used in analysing the heat transfer in the induction furnace. The literatures has not analysed an induction furnace in detailed way to fully develop a formulation for the thickness of the composite wall and the applications of the literatures were oriented in the general rather a particular induction furnace with constraints. The formulation of FEM was decided for the heat transfer analysis of induction furnace and the simulation will be performed for the validation of the recently modified composite wall thickness.

II. THERMAL MODELLING OF INDUCTION PROCESS

A. Governing Equation –

The heat transfer analysis of the induction furnace is governed by the thermal diffusion equation in cylindrical form and it is given by equation (1) .

$$\frac{1}{R} \frac{\partial}{\partial R} \left( kR \frac{\partial T}{\partial R} \right) = C_s \rho \frac{\partial T}{\partial t} \tag{1}$$

Where  $C_s$  is the specific heat capacity of the wall material,  $\rho$  is the density of the wall material, and  $R$ ,  $\theta$  and  $Z$  are cylindrical coordinates[8].

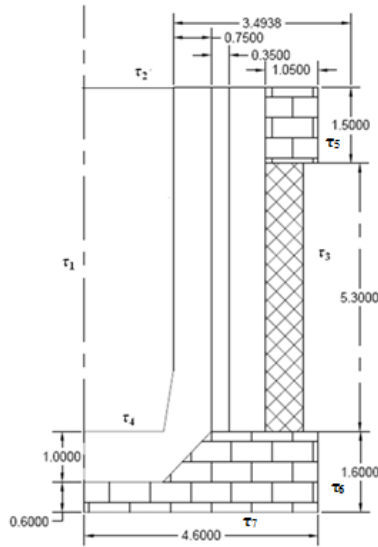

Fig.2 Domain of the Induction furnace

B. Boundary Conditions:

1. On  $\tau_1, \tau_2, \tau_5, \tau_6, \tau_7$

$$\frac{1}{R} \frac{\partial}{\partial R} \left( kR \frac{\partial T}{\partial R} \right) = 0$$

2. On  $\tau_3$ ,

$$\frac{1}{R} \frac{\partial}{\partial R} \left( kR \frac{\partial T}{\partial R} \right) = q_w$$

3. On  $\tau_4$ ,

$$\frac{1}{R} \frac{\partial}{\partial R} \left( kR \frac{\partial T}{\partial R} \right) = h(T - T_o)$$

Where  $q_w$  is given by,

$$q_w = \frac{(1/2)I^2 Lt}{A_r}$$

$$L = \frac{\mu_o \mu_r N^2 A}{l}$$

Fig.2 shows the domain considered for the analysis and in this work, the domain is symmetric about the axis hence the axis symmetric condition has been taken for the purpose of the analysis and to reduce the complexity in the computation. The composite wall is consisting of ramming mass, mica, sintering cylinder and ceramic wall. The boundary conditions considered for the calculation is shown above. The axis symmetric condition is applied along the axis and boundary along  $\tau_1$  is considered as insulated i.e. There is no heat exchange across the boundaries  $\tau_1$ ,  $\tau_2$ ,  $\tau_5$ ,  $\tau_6$  and  $\tau_7$ . The coil is rounded around the boundaries  $\tau_3$ ,  $\tau_4$  and hence the heat flux is entering through it. The heat flux condition has been depicted in the boundary condition across those boundaries [9-12].

The heat flux calculation is governed by the induction of the coil. The inductance of the coil is required in the calculation of the heat flux input. For the present study the parameters of the furnace used in the industries has been adopted for the calculations. The coil is having 15 numbers of turns around the furnace. The permeability and cross section of the coil determines the inductance. The amount of the heat flux enters through the composite wall is greatly governed by the different combinations of the composite wall thickness as well. The diameter of the furnace is about 600 mm and the calculations have shown that the 15000 W/m<sup>2</sup> amount of heat flux acts on the furnace.

*C. Thermal stress*

The thermal stress distribution is calculated by determining the temperature distribution from the thermal analysis. In this, the materials which are less in temperature will be reluctant for the expansion and hence prevents the expansion of the layers of material with higher temperature. This restrictions induces the stress in the material of the induction furnace. The different layers of the induction furnace wall having different materials results in the different thermal coefficient of expansion. The variance of thermal expansion also induces the thermal stress. In ANSYS the input properties of the materials will be used for the calculation of the thermal stress [13-15].

*D. Simulation of Induction Process*

Fig.2 shows the 3-D CAD model developed in Pro-E. The model was developed according to the present induction furnace dimensions. The boundary conditions are applied based on the working condition for the purpose of simulation.



Figure 3. Thermal model of the induction furnace without the ceramic wall and with induction coil

The simulation will be performed in ANSYS and the parametric analysis will be performed for different composite wall thickness with heat transfer between the wall by measuring the temperature across it. The input taken for the simulation is shown in the Table.1. The simulation of induction furnace for the melting of the brass metal is typically a 2-phase problem which needs more attention towards the melting of brass metal into liquid phase. But for the present work the two-phase problem is converted into single phase considering only the metal remaining in the chamber which needs to be melted. It is assumed that the metal after melting goes and settles down and provides convective boundary to the present solid phase metal. The present work is interested in determining the amount of heat required for the melting of the entire brass metal for the different combination of thickness of the composite wall and neglecting the temperature distribution within the liquid phase of the metal [16-20].

III. RESULTS AND DISCUSSIONS

The simulation has been carried out and the results are plotted in the graph. The ramming mass thickness was taken as the major concern of the simulation for the effective heat transfer and the adequate strength to withstand the ramming mass for the melting of the brass materials was also considered. The simulation results correspond to the temperature distribution for one hour duration.

TABLE -1  
MATERIAL PROPERTIES OF THE DIFFERENT RAMMING MASS

Material Properties	Silica Ramming Mass	Alumina Ramming Mass	Magnesia Ramming Mass	Zirconia
Elastic Constant (GPa)	180	220	210	210
Poisson's Ratio	0.22	0.22	0.21	0.22
Density(kg/m <sup>3</sup> )	2800	3400	3600	5000
Thermal Expansion Coefficient(μm/°C)	6.8	7.2	8.6	3.5
Thermal Conductivity(W/mK)	11	16	15	7.5
Specific Heat	950	920	880	780

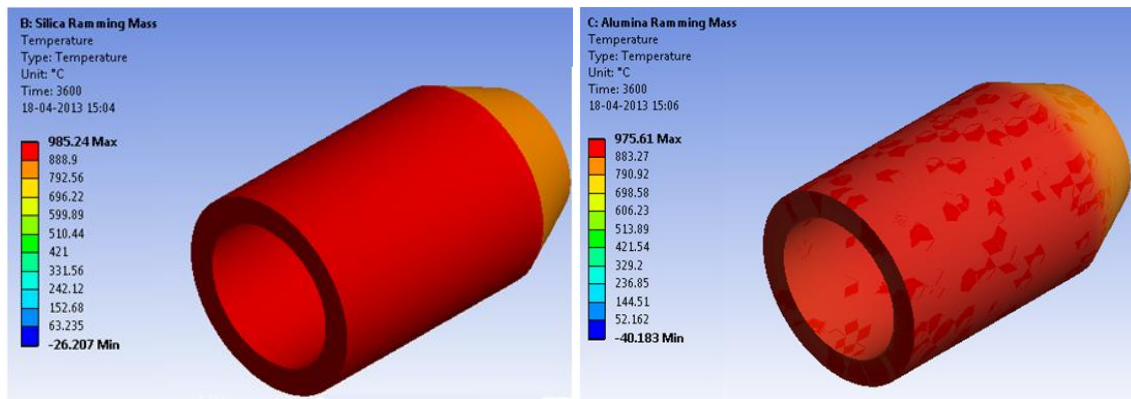

(a)

(b)

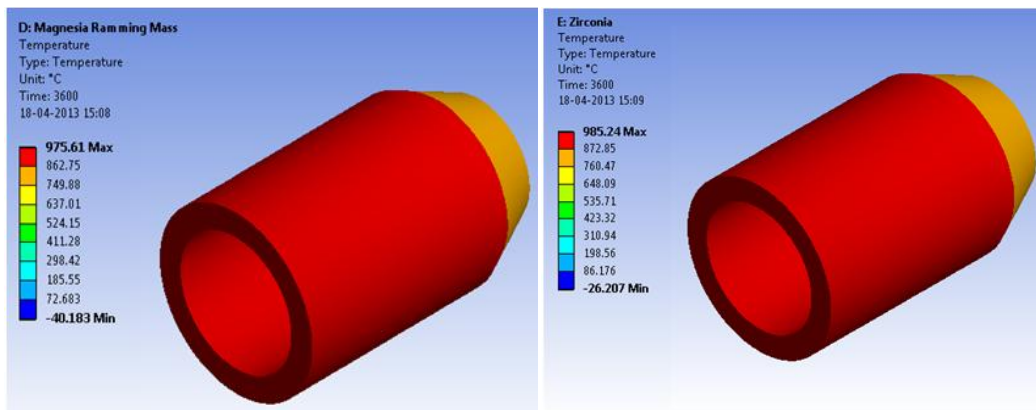

(c)

(d)

Fig.4 Temperature distribution in the induction furnace wall for different ramming mass materials (a) Silica ramming mass (b) Alumina ramming mass (c) Magnesia ramming mass (d) Zirconia

The result of simulation for different materials having same wall thickness (75 mm) is shown in the Fig. 4. The maximum temperatures reached in all the cases are dependent on thermal properties of the materials. It is observed that the silica which is having thermal conductivity relatively lesser than other materials still produces the better inner wall temperature as it is due to the fact that temperature distribution don't depend only on thermal conductivity but also on density of the material. The density as well resists the transfer of heat so it is obvious that the proper combination of density and thermal conductivity has to be taken care for the wall material. The objective of the simulation also includes the validation of wall thickness for the analysis. The present wall thickness (75 mm) produces reasonable results but still it is required to verify dimensions of the wall thickness and need to validated the thickness of the wall by comparing the results of simulation in different others thickness. The results of the analysis are shown in the Fig.5. The simulation result of silica is shown in Fig.5 (b) as it gives better temperature distribution; it is taken for the further simulation process.

Fig.5(a) shows that the reduction in the silica ramming mass thickness makes the heat transfer to increase so temperature goes up for lesser thickness. The graph favours to have lesser and lesser thickness of the silica ramming mass so that the heat transfer will be effective but together with the heat transfer, the strength criteria also required to be verified for the validity of the design.

Fig.5 (b) shows the effectiveness of different ramming masses for the heat transfer. The thermal conductivity can be increased by adding suitable ingredient and also by altering the composition of the ramming mass. For the present study, silica ramming mass, alumina ramming mass, magnesiar ramming mass and Zirconia were taken and their properties are given in the Table 1 The graph plotted shows the temperature dependency on both density and thermal conductivity. Silica ramming mass produces a maximum temperature of about 1537.6 K for the wall thickness 60 mm. The graph shows the silica ramming mass has highest temperature for the same input among other materials and it is also easily available.

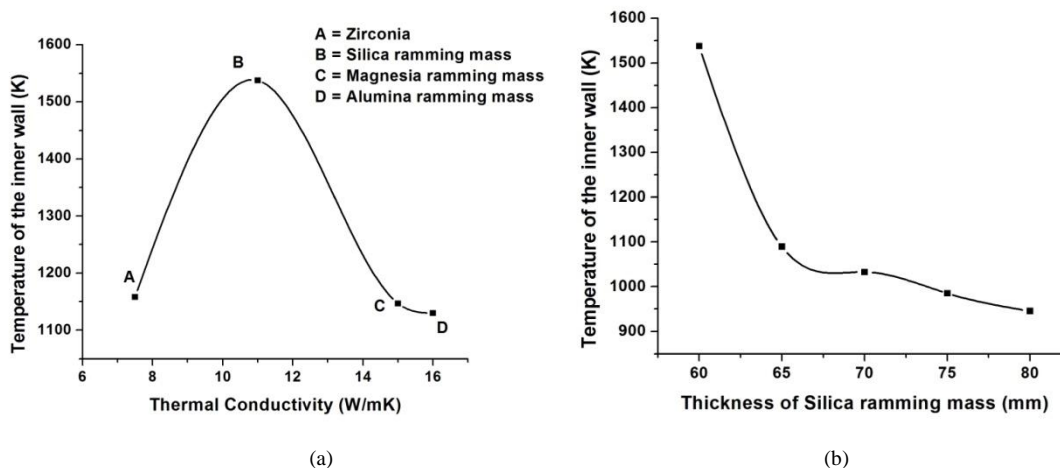

Fig.5 Plot of Temperature of the inner wall (a) conductivity of ramming mass (b) Thickness of Ramming mass

#### IV. CONCLUSION

The analysis has been carried out for the effective heat transfer of the induction process. The results show the effectiveness of ramming mass in the melting process. It plays an important role in the process. The simulation performed shows the proper thickness and conductivity of it would enhance the melting and optimizes the heat process. The result also highlights the application of FEM in the computation calculations of induction process. The FEM serves better in providing the results with adequate accuracy. The further analysis has to be extended for the time dependent input loading of the furnace which will reveal the fatigue related behavior of the furnace.

#### ACKNOWLEDGMENT

The author would like to thank department of mechanical engineering, school of engineering, RK University Rajkot, for extending the facilities for the research work.

#### REFERENCES

- [1] A. O'zel, V. Ucar, A. MimarogluU, I. Calli "Comparison of the thermal stresses developed in diamond and advanced ceramic coating systems under thermal loading" Materials and Design, Vol. 21, pp. 437-440, 2000.
- [2] H.K. Jung, "The induction heating process of semi-solid aluminum alloys for thixoforming and their microstructure evaluation", Journal of Materials Processing Technology, Vol. 105, pp.176-190, 2000.

- [3] Dae-Cheol Ko, Gyu-Sik Min, Byung-Min Kim, Jae-Chan Choi, "Finite element analysis for the semi-solid state forming of aluminum alloy considering induction heating", *Journal of Materials Processing Technology*, Vol.100, pp. 95-104, 2000
- [4] L.P. Borrego , J.M. Ferreira , J.M. Pinho da Cruz ,J.M. Costa, " Evaluation of overload effects on fatigue crack growth and closure", *Engineering Fracture Mechanics*, Vol. 70,pp.1379–1397, 2003.
- [5] Y. Favennec , V. Labbe, F. Bay, "Induction heating processes optimization a general optimal control approach", *Journal of Computational Physics*, Vol.187, pp.68–94,2003.
- [6] Ki Wan Kim and Seung Wook Baek, "Inverse Surface Radiation Analysis In An Axisymmetric Cylindrical Enclosure Using A Hybrid Genetic Algorithm", *Numerical Heat Transfer, Part A*, Vol.46,pp.367–381, 2004.
- [7] Vivek R. Gandhewar, Satish V. Bansod, Atul B.Borade, "Induction Furnace - A Review", *International Journal of Engineering and Technology*, Vol.3, pp.277-284,2011
- [8] A. A. Bhat, S. Agarwal, D. Sujish, B. Muralidharan, B.P. Reddy, G.Padmakumar and K.K.Rajan , " Thermal Analysis of Induction Furnace", proceedings of the COMSOL Bangalore 2012.
- [9] M. Ben Salah, F. Askri, K. Slimi, S. Ben Nasrallah, " Numerical resolution of the radiative transfer equation in a cylindrical enclosure with the finite-volume method" *International Journal of Heat and Mass Transfer* Vol.47, pp.2501–2509. 2004
- [10] Ozkan Sarikaya, Yasar Islamoglu, Erdal Celik, "Finite element modelling of the effect of the ceramic coating on heat transfer characteristics in thermal barrier applications" *Materials and Design* Vol.26,pp.357–362,2005.
- [11] Man Young Kim, Seung Wook Baek, "Modeling of radiative heat transfer in an axisymmetric cylindrical enclosure with participating medium", *Journal of Quantitative Spectroscopy & Radiative Transfer* Vol.090, pp.377–388,2005.
- [12] J.C.Chai and Parth "Discrete-Ordinates and Finite-Volume Methods for Radiation Heat Transfer", *Treatment of Thermal Radiation in Heat Transfer Problems*, IIT Guwahati jan2-3, 2006.
- [13] Man Young Kim "Assessment of the axisymmetric radiative heat transfer in a cylindrical enclosure with the finite volume method" *International Journal of Heat and Mass Transfer* Vol.51,pp.5144–5153. ,2008.
- [14] Joel J. Schubbe, "Evaluation of fatigue life and crack growth rates in 7050-T7451 aluminum plate for T-L and L-S oriented failure under truncated spectra loading", *Engineering Failure Analysis* Vol.16, pp.340–349,2009.
- [15] Subhash C. Mishra, Man Young Kim, Ranjan Das, M. Ajith, and R. Uppaluri "Lattice Boltzmann Method Applied to the Analysis of Transient Conduction radiation Problems in a Cylindrical Medium " *Numerical Heat Transfer, Part A*, Vol.56,pp.42–59, 2009.
- [16] Raoudha Chaabane, Faouzi Askri, Sassi Ben Nasrallah," Transient Combined Conduction and Radiation in a Two-Dimensional Participating Cylinder in Presence of Heat Generation", *World Academy of Science, Engineering and Technology* 55, 2011.
- [17] Subhash C. Mishra, Man Young Kim, "Analysis Of Conduction And Radiation Heat Transfer In A 2-D Cylindrical Medium Using The Modified Discrete Ordinate Method And The Lattice Boltzmann Method" *Numerical Heat Transfer, Part A*, Vol.60,pp.254–287, 2011.
- [18] N.A. Kadhim, S. Abdullah, A.K. Ariffin , "Effective strain damage model associated with finite element modeling and experimental validation" *International Journal of Fatigue* Vol.36 pp.194–205,2012
- [19] Vital LeDez n, Hamou Sadat, "Radiative transfer in a semi-transparent medium enclosed in a cylindrical annulus" *Journal of Quantitative Spectroscopy & Radiative Transfer*, Vol.113,pp. 96–116,2012.
- [20] Sudhakar Matle, S.Sundar, "Axi-symmetric 2D simulation and numerical heat transfer characteristics for the calibration furnace in a rectangular enclosure" *Applied Mathematical Modelling*, Vol 36,pp.878–893,2012
- [21] JN Reddy, *An Introduction to the Finite Element Method (Engineering Series) McGraw-Hill Science/Engineering/Math*; 3 editions.
- [22] Daryl Logan, "A First Course in he Finite Element Method", 4th Edition, Cengage Learning, 2007.